



# VCU

Virginia Commonwealth University  
**VCU Scholars Compass**

---

Statistical Sciences and Operations Research  
Publications

Dept. of Statistical Sciences and Operations  
Research

---

2012

## Coverings and matchings in $r$ -partite hypergraphs

Douglas S. Altner  
*United States Naval Academy*

J. Paul Brooks  
*Virginia Commonwealth University, jpbrooks@vcu.edu*

Follow this and additional works at: [http://scholarscompass.vcu.edu/ssor\\_pubs](http://scholarscompass.vcu.edu/ssor_pubs)

 Part of the [Computer Sciences Commons](#), and the [Mathematics Commons](#)

Copyright © Wiley This is the peer reviewed version of the following article: Altner, D. S. and Brooks, J. P. (2012), Coverings and matchings in  $r$ -partite hypergraphs. *Networks*, 59: 400–410, which has been published in final form at <http://dx.doi.org/10.1002/net.20459> This article may be used for non-commercial purposes in accordance with Wiley Terms and Conditions for self-archiving.

---

Downloaded from

[http://scholarscompass.vcu.edu/ssor\\_pubs/4](http://scholarscompass.vcu.edu/ssor_pubs/4)

This Article is brought to you for free and open access by the Dept. of Statistical Sciences and Operations Research at VCU Scholars Compass. It has been accepted for inclusion in Statistical Sciences and Operations Research Publications by an authorized administrator of VCU Scholars Compass. For more information, please contact [libcompass@vcu.edu](mailto:libcompass@vcu.edu).

# Coverings and Matchings in $r$ -Partite Hypergraphs

Douglas S. Altner

Department of Mathematics, United States Naval Academy,  
Annapolis, Maryland, altner@usna.edu.

J. Paul Brooks

Department of Statistical Sciences and Operations Research, Virginia Commonwealth University,  
Richmond, Virginia, jpbrooks@vcu.edu.

June 8, 2011

## Abstract

Ryser's conjecture postulates that, for  $r$ -partite hypergraphs,  $\tau \leq (r - 1)\nu$  where  $\tau$  is the covering number of the hypergraph and  $\nu$  is the matching number. Although this conjecture has been open since the 1960s, researchers have resolved it for special cases such as for intersecting hypergraphs where  $r \leq 5$ . In this paper, we prove several results pertaining to matchings and coverings in  $r$ -partite intersecting hypergraphs. First, we prove that finding a minimum cardinality vertex cover for an  $r$ -partite intersecting hypergraph is NP-hard. Second, we note Ryser's conjecture for intersecting hypergraphs is easily resolved if a given hypergraph does not contain a particular sub-hypergraph, which we call a *tornado*. We prove several bounds on the covering number of tornados. Finally, we prove the integrality gap for the standard integer linear programming formulation of the maximum cardinality  $r$ -partite hypergraph matching problem is at least  $r - k$  where  $k$  is the smallest positive integer such that  $r - k$  is a prime power.

**Key words.** covering, matching, Ryser's conjecture,  $r$ -partite hypergraphs, intersecting hypergraphs

## 1 Introduction

Finding a maximum cardinality matching in an  $r$ -partite hypergraph is a well-studied problem in combinatorics, combinatorial optimization, and computer science that is known as the  $r$ -Dimensional Matching Problem (rDM). rDM is NP-hard when  $r \geq 3$  [7]. A related problem is that of finding a minimum cardinality vertex cover (rDVC) in an  $r$ -partite hypergraph. This problem is also NP-hard for  $r \geq 3$  [6].

The relationship between the size  $\tau$  of a minimum cardinality vertex cover and the size  $\nu$  of a maximum cardinality matching in an  $r$ -partite hypergraph is the subject of an open conjecture due to Ryser, which is stated as follows:

**Ryser’s Conjecture.** For an  $r$ -partite hypergraph,  $\tau \leq (r - 1)\nu$ .

The case when  $r = 2$  is the subject of König’s Theorem [8] for bipartite covering and matching. Aharoni [2] proves the conjecture when  $r = 3$ . The conjecture remains open for  $r \geq 4$ . Tuza [13] proves the conjecture is true for intersecting hypergraphs when  $r = 4$  and  $r = 5$ . The conjecture remains open for intersecting hypergraphs when  $r \geq 6$ .

There are other cases when Ryser’s conjecture is known to be true. Berge [3] establishes that any polytope defined by:

$$\{x \in \mathcal{R}^n : Ax \leq b; x \geq 0\} \quad \text{or} \quad \{x \in \mathcal{R}^n : Ax \geq b; x \geq 0\}$$

where  $A$  is a  $\{0, 1\}$  matrix has integral vertices if and only if  $A$  is a balanced matrix and  $b$  is a vector of positive integers. An implication of Berge’s result is that rDM and rDVC can be solved with linear programming if the incidence matrix of the underlying hypergraph is a balanced matrix. If this is the case, then the strong duality theorem of linear programming implies  $\tau = \nu$  for hypergraphs with balanced incidence matrices. Thus, Ryser’s conjecture is easily resolved for hypergraphs with balanced incidence matrices.

Since rDM and rDVC can occur on hypergraphs having incidence matrices that are not balanced, the standard integer linear programming (ILP) formulation of rDM has a nontrivial integrality gap. Note that the LP relaxations of the standard ILP of rDM and of rDVC form a primal-dual LP pair. Therefore, a cover for a given hypergraph provides an upper bound on the integrality gap for the rDM ILP formulation. If Ryser’s conjecture is true it would provide an upper bound of  $r - 1$  on the integrality gap for rDM. However, this upper bound is already known to be true due to the following result of Füredi:

**Füredi’s Theorem** [5] *For an  $r$ -partite hypergraph,  $\tau^* \leq (r - 1)\nu$ .*

In this context,  $\tau^*$  refers to the cardinality of the minimum fractional vertex cover in the hypergraph. Füredi’s Theorem is tight for the case when  $r$  is a prime power. This can be shown by constructing an instance of rDM on the hypergraph that results from deleting a vertex and all incident hyperedges from the projective plane of order  $r$  [2, 4, 12].

There are also known bounds on the integrality gaps of the standard formulations of rDVC. Lovász [11] proves the ratio obtained by dividing the cardinality of the minimum vertex cover in a plain (i.e., not necessarily  $r$ -partite) hypergraph by the cardinality of the minimum fractional vertex cover

is at most  $1 + \log d$  where  $d$  is the maximum degree in the hypergraph. Naturally, this result also extends to the integrality gap of rDVC. Lovász [10] also proves the integrality gap of rDVC is at most  $\frac{r}{2}$ .

This paper makes several contributions related to covers and matchings in  $r$ -partite hypergraphs. First, we prove that rDVC in intersecting hypergraphs is NP-hard for  $r \geq 3$ . We observe that an  $r$ -partite intersecting hypergraph with  $\tau \neq \nu$  must contain a certain sub-hypergraph, which we call a *tornado*. We prove several upper bounds on the size of minimum cardinality covers for tornados. Finally, we present a proof that the integrality gap of the standard ILP formulation for rDM is at least  $r - k$ , where  $k$  is the smallest positive integer such that  $r - k$  is a prime power.

Our last contribution is an extension of a known result; specifically, there exists an intersecting hypergraph with  $\tau = r - 1$  if  $r$  is a prime power (e.g., Mansour et al. [12]). This result is combined with Füredi's Theorem and presented in terms of the integrality gap for the standard ILP formulation for rDM.

## 2 Preliminaries

In this section we outline preliminary concepts that are used throughout this paper. Specifically, we present preliminary concepts for edge colorings, hypergraphs, integer programming, and Latin squares.

### 2.1 Hypergraphs

Let  $H = (V, E)$  denote an undirected hypergraph with vertex set  $V$  and hyperedge set  $E$ . A hyperedge  $e \in E$  is a subset of the vertices. That is,  $e \subseteq V$  for each  $e \in E$ . A hypergraph is  *$r$ -partite* if the vertices are partitioned into  $r$  disjoint subsets  $V_k$ ,  $k = 1, \dots, r$ , and each hyperedge contains exactly one vertex from each of the  $r$  subsets. All hypergraphs discussed in this paper are  $r$ -partite.

An *incidence matrix*  $A$  of a hypergraph is a  $\{0, 1\}$  matrix where every vertex has exactly one corresponding row in  $A$ , every hyperedge has exactly one corresponding column in  $A$  and the entry in the row corresponding to vertex  $v$  and the column corresponding to hyperedge  $e$  is 1 if and only if  $v$  is contained in  $e$ . An incidence matrix is *balanced* [3] if it does not contain a submatrix that is equivalent to an incidence matrix of a graph that is an odd cycle. A hypergraph with a balanced incidence matrix is a *balanced* hypergraph. A hypergraph is *intersecting* if each pair of hyperedges has a non-empty intersection.

A *matching* in a hypergraph is a subset of hyperedges  $\mathcal{M} \subseteq E$  such that each vertex appears in at most one of the hyperedges in  $\mathcal{M}$ . A *vertex cover* in a hypergraph is a subset of the vertices  $C \subseteq V$  such that every hyperedge contains at least one of the vertices in  $C$ .

A *fractional vertex cover*  $C_f$  is an assignment of weights to vertices such that every vertex receives a weight in the closed interval from 0 to 1 and the sum of the weights of vertices on each hyperedge is greater than or equal to one.  $|C_f|$  denotes the *cardinality* of a fractional vertex cover  $C_f$ , which is the sum of the weights in the fractional vertex cover.

## 2.2 Edge Colorings of Graphs

Let  $G = (V, E)$  be a graph. An *edge coloring* is a partition of the edges into subsets where each subset uniquely corresponds to a color. An edge that is in the subset corresponding to color  $c$  is *colored* with color  $c$ . An edge coloring is *proper* if no two edges that are incident to the same vertex are colored with the same color. Let  $K_n$  be the complete graph on  $n$  vertices. The following theorem is well known:

**Theorem 1.** [14] *There exists a proper edge coloring of  $K_{2n}$  that uses  $2n - 1$  colors.*

## 2.3 Integer Programming

Given an instance  $I$  of an ILP formulation of a combinatorial optimization problem where the objective is to maximize a function, let  $z_{IP}^*(I)$  denote its optimal objective value. Let  $z_{LP}^*(I)$  denote the optimal objective value of a corresponding *linear programming (LP) relaxation*, the linear program obtained by replacing the integrality restrictions on the variables with nonnegativity constraints. The *integrality gap* of this particular instance (for this particular ILP and LP relaxation pair) is  $\frac{z_{LP}^*(I)}{z_{IP}^*(I)}$ . Similarly, the *integrality gap* of this ILP (and a corresponding LP relaxation) equals:

$$\sup_{I \in \mathcal{I}} \frac{z_{LP}^*(I)}{z_{IP}^*(I)},$$

where  $\mathcal{I}$  is the set of all possible instances of the problem. Note the integrality gap of any ILP is always greater than or equal to one. An ILP with an integrality gap of exactly one is said to have no integrality gap.

## 2.4 Latin Squares

Let  $[n] = \{1, 2, \dots, n\}$ . A *Latin square* of dimension  $n$  is an  $n \times n$  matrix where each number in  $[n]$  occurs in each row exactly once and each number in  $[n]$  occurs in each column exactly once. Such a Latin square has *size*  $n$ .

Given two square matrices  $L_1$  and  $L_2$  of size  $n$ , their *paired matrix* is a square matrix  $L_{1,2}$  of dimension  $n$  such that the entry in the  $i$ th row and the  $j$ th column of  $L_{1,2}$  is an ordered pair  $(a_1, a_2)$  where  $a_1$  is the element in the  $i$ th row and the  $j$ th column of  $L_1$  and  $a_2$  is the element in the  $i$ th row and the  $j$ th column of  $L_2$ .

Two Latin squares are *orthogonal* if their corresponding paired matrix contains each of the ordered pairings in the set  $[n] \times [n]$  exactly once. A set of pairwise orthogonal Latin squares are called *mutually orthogonal Latin squares (MOLS)*.

A well-known result concerning the existence of MOLS is the following:

**Theorem 2.** [1] *A set of  $n - 1$  distinct MOLS of dimension  $n$  exists if  $n$  is a prime power.*

## 3 Covering $r$ -Partite Intersecting Hypergraphs is NP-hard

Let IrDVC denote the special case of rDVC on intersecting hypergraphs. We provide a nontrivial reduction of rDVC to IrDVC to prove IrDVC is NP-hard. First, we need the following definitions:

**Definition 1.** *Let  $f : V \rightarrow [2n-1]$  be a proper edge coloring of  $K_{2n}$ . Then a **tournament function**  $\pi : V \times [2n-1] \rightarrow V$  is a function that, given a vertex  $u$  and a color  $c$  as input, outputs the vertex  $v$  such that the edge  $(u, v)$  has color  $c$  when the edge coloring  $f$  is applied to  $K_{2n}$ .*

We use the name *tournament function* because if we were to schedule a single round-robin tournament between the vertices (players) using the well-known circle method of Kirkman [9],  $\pi$  would indicate the opponent of vertex  $u$  during the week that corresponds to color  $c$ .

**Definition 2.** *Let  $H = (V, E)$  be a hypergraph and let  $C \subseteq V$  be a vertex cover of  $H$ . A vertex  $v \in C$  **minimally covers** a hyperedge  $e \in E$  if the vertex set  $C \setminus \{v\}$  does not cover  $e$ .*

**Theorem 3.** *IrDVC is NP-hard for  $r \geq 5$ .*

*Proof.* Consider any instance of rDVC where  $r \geq 5$  and let  $H = (\bigcup_{i=1}^r V_i, E)$  be the corresponding hypergraph. We show how to transform this instance into an instance of IrDVC, which is on a hypergraph  $\hat{H} = (\bigcup_{i=1}^{\hat{r}} \hat{V}_i, \hat{E})$  where  $\hat{r} = r + 2(|E| - 1)$ . Assume for now that  $|E|$  is even.

For each  $i \in \{1, 2, \dots, r\}$ ,  $\hat{V}_i = V_i$ . In addition, for each hyperedge  $e_i \in E$  and for each vertex subset  $V_j$  such that  $j > r$ , create a vertex  $v_{i,j}$  in partition  $\hat{V}_j$ . For each hyperedge  $e_i = (v_{(i,1)}, v_{(i,2)}, \dots, v_{(i,r)})$  in  $E$ , create the following two hyperedges in  $\hat{E}$ :

- $\hat{e}_{(i,1)} = (v_{(i,1)}, v_{(i,2)}, \dots, v_{(i,r)}, v_{(\psi(i,r+1),r+1)}, v_{(\psi(i,r+2),r+2)}, \dots, v_{(\psi(i,\hat{r}),\hat{r})})$ ,
- $\hat{e}_{(i,2)} = (v_{(i,1)}, v_{(i,2)}, \dots, v_{(i,r)}, v_{(\omega(i,r+1),r+1)}, v_{(\omega(i,r+2),r+2)}, \dots, v_{(\omega(i,\hat{r}),\hat{r})})$ ,

where

$$\psi(i, r+p) := \begin{cases} \pi(i, \lfloor \frac{p}{2} \rfloor) & \text{if } \pi(i, \lfloor \frac{p}{2} \rfloor) < i \text{ and } p \text{ is odd} \\ i & \text{otherwise} \end{cases},$$

$$\omega(i, r+p) := \begin{cases} i & \text{if } \psi(i, r+p) = \pi(i, \lfloor \frac{p}{2} \rfloor) \\ \pi(i, \lfloor \frac{p}{2} \rfloor) & \text{otherwise} \end{cases},$$

and  $\pi$  is a tournament function on the complete graph  $K_{2|E|}$  such that:

- Each hyperedge in  $H$  corresponds to a vertex in  $K_{2|E|}$ .
- The  $p$ th color on edge  $(i, j)$  in  $K_{2|E|}$  indicates each of the two hyperedges corresponding to  $e_i$  intersects one of the two hyperedges corresponding to  $e_j$  in the  $(2p-1)$ st partition of  $\hat{H}$  and intersects the other one in the  $(2p)$ th partition of  $\hat{H}$ .

By construction,  $\hat{H}$  is an intersecting,  $\hat{r}$ -partite hypergraph where  $|\hat{V}| = |V| + 2|E|(|E| - 1)$  and  $|\hat{E}| = 2|E|$ . Thus, the input size of  $\hat{H}$  is a polynomial function of  $r$ ,  $|V|$ , and  $|E|$ , which makes this a polynomial reduction.

What remains to show is that  $\tau(H) = \tau(\hat{H})$ . Clearly,  $\tau(\hat{H}) \leq \tau(H)$  since the minimum vertex cover of  $H$  has a corresponding cover in  $\hat{H}$ .

We now show  $\tau(H) \leq \tau(\hat{H})$ . Let  $\hat{V}_L = \bigcup_{i=1}^r \hat{V}_i$  and let  $\hat{V}_R = \bigcup_{i=r+1}^{\hat{r}} \hat{V}_i$ . Let  $\hat{C}$  be a minimum vertex cover of  $\hat{H}$  that is minimal with respect to the cardinality of  $\hat{C} \cap \hat{V}_R$ . Every vertex  $v \in \hat{C} \cap \hat{V}_R$  must minimally cover exactly two hyperedges since if it only minimally covered one hyperedge  $\hat{e}_{(i,j)}$ , then this would contradict the minimality of  $\hat{C}$  since a new minimum vertex cover could be formed from  $\hat{C}$  that replaces  $v$  with any vertex in  $\hat{V}_L \cap \hat{e}_{(i,j)}$ , which would use fewer vertices from  $\hat{V}_R$ .

Furthermore, for any  $i$ , hyperedge  $\hat{e}_{(i,1)}$  is minimally covered by a vertex in  $\hat{C} \cap \hat{V}_R$  if and only if hyperedge  $\hat{e}_{(i,2)}$  is minimally covered by a vertex in  $\hat{C} \cap \hat{V}_R$ . This is because a vertex in  $\hat{C} \cap \hat{V}_L$  covers  $\hat{e}_{(i,1)}$  if and only if it also covers  $\hat{e}_{(i,2)}$ .

Therefore, the vertices in  $\hat{C} \cap \hat{V}_R$  must collectively minimally cover a set of hyperedges of the form:

$$\{\hat{e}_{(p(1),1)}, \hat{e}_{(p(1),2)}, \hat{e}_{(p(2),1)}, \hat{e}_{(p(2),2)}, \dots, \hat{e}_{(p(m_R),1)}, \hat{e}_{(p(m_R),2)}\} \text{ where } m_R = |\hat{C} \cap \hat{V}_R|.$$

This means there exists an alternative minimum vertex cover that can be constructed by removing all of the vertices in  $\hat{C} \cap \hat{V}_R$  from  $\hat{C}$  and replacing them with one vertex from each of the following vertex sets:  $\hat{e}_{(p(1),1)} \cap V_L, \hat{e}_{(p(2),1)} \cap V_L, \dots, \hat{e}_{(p(m_R),1)} \cap V_L$ . However, this contradicts the minimality of  $\hat{C}$ . Thus, any minimum vertex cover for  $\hat{H}$  is also a minimum vertex cover for  $H$ , which implies that  $\tau(\hat{H}) = \tau(H)$ .

Finally, if  $|E|$  is odd,  $\hat{H}$  can be constructed as follows:

1. Create a phantom  $r$ -partite hyperedge  $e_{|E|+1}$  on an arbitrary set of vertices to ensure the number of hyperedges is even.
2. Construct  $\hat{H}$  as described above.
3. Remove the two hyperedges extended from  $e_{|E|+1}$  in  $\hat{H}$ .

The same reasoning shows that  $\tau(\hat{H}) = \tau(H)$  when  $|E|$  is odd. □

For illustrative purposes, we describe a small example of constructing  $\hat{H}$ .

**Example of Construction:** Suppose  $H = (V, E)$  where  $E$  consists of the following four hyperedges:

1.  $e_1 = (v_{(1,1)}, v_{(1,2)}, \dots, v_{(1,r)})$ ,
2.  $e_2 = (v_{(2,1)}, v_{(2,2)}, \dots, v_{(2,r)})$ ,
3.  $e_3 = (v_{(3,1)}, v_{(3,2)}, \dots, v_{(3,r)})$ ,
4.  $e_4 = (v_{(4,1)}, v_{(4,2)}, \dots, v_{(4,r)})$ .

Note that it is possible for any of these four hyperedges to intersect in  $H$  (i.e.,  $v_{(i_1,j)} = v_{(i_2,j)}$  for hyperedges  $e_{i_1}$  and  $e_{i_2}$  and some subset  $j$ ), but they need not intersect.

Then we can construct  $\hat{H}$  by including the original  $r$  subsets of vertices, creating six new subsets of vertices, and including the following eight hyperedges:

1.  $\hat{e}_{1,1} = (v_{(1,1)}, v_{(1,2)}, \dots, v_{(1,r)}, v_{(1,r+1)}, v_{(1,r+2)}, v_{(1,r+3)}, v_{(1,r+4)}, v_{(1,r+5)}, v_{(1,r+6)})$ ,
2.  $\hat{e}_{1,2} = (v_{(1,1)}, v_{(1,2)}, \dots, v_{(1,r)}, v_{(2,r+1)}, v_{(2,r+2)}, v_{(3,r+3)}, v_{(3,r+4)}, v_{(4,r+5)}, v_{(4,r+6)})$ ,
3.  $\hat{e}_{2,1} = (v_{(2,1)}, v_{(2,2)}, \dots, v_{(2,r)}, v_{(1,r+1)}, v_{(2,r+2)}, v_{(2,r+3)}, v_{(2,r+4)}, v_{(2,r+5)}, v_{(2,r+6)})$ ,
4.  $\hat{e}_{2,2} = (v_{(2,1)}, v_{(2,2)}, \dots, v_{(2,r)}, v_{(2,r+1)}, v_{(1,r+2)}, v_{(4,r+3)}, v_{(4,r+4)}, v_{(3,r+5)}, v_{(3,r+6)})$ ,



5.  $\hat{e}_{3,1} = (v_{(3,1)}, v_{(3,2)}, \dots, v_{(3,r)}, v_{(3,r+1)}, v_{(3,r+2)}, v_{(1,r+3)}, v_{(3,r+4)}, v_{(2,r+5)}, v_{(3,r+6)})$ ,
6.  $\hat{e}_{3,2} = (v_{(3,1)}, v_{(3,2)}, \dots, v_{(3,r)}, v_{(4,r+1)}, v_{(4,r+2)}, v_{(3,r+3)}, v_{(1,r+4)}, v_{(3,r+5)}, v_{(2,r+6)})$ ,
7.  $\hat{e}_{4,1} = (v_{(4,1)}, v_{(4,2)}, \dots, v_{(4,r)}, v_{(3,r+1)}, v_{(4,r+2)}, v_{(2,r+3)}, v_{(4,r+4)}, v_{(1,r+5)}, v_{(4,r+6)})$ ,
8.  $\hat{e}_{4,2} = (v_{(4,1)}, v_{(4,2)}, \dots, v_{(4,r)}, v_{(4,r+1)}, v_{(3,r+2)}, v_{(4,r+3)}, v_{(2,r+4)}, v_{(4,r+5)}, v_{(1,r+6)})$ .

In this example,  $\hat{V}_L = \cup_{i=1}^r \hat{V}_i$  and  $\hat{V}_R = \cup_{i=r+1}^{r+6} \hat{V}_i$ . The sub-hypergraph in  $\hat{V}_R$  corresponds to a proper edge coloring of  $K_4$  with three color classes. Let  $u_1, u_2, u_3, u_4$  be the vertices of  $K_4$ . Hyperedge  $e_i$  in  $H$  corresponds to vertex  $u_i$  in  $K_4$  for  $i = 1, 2, 3, 4$  and the newly-added vertex subsets  $\hat{V}_{r+1}$  and  $\hat{V}_{r+2}$  correspond to the first color class,  $\hat{V}_{r+3}$  and  $\hat{V}_{r+4}$  correspond to the second color class, and  $\hat{V}_{r+5}$  and  $\hat{V}_{r+6}$  correspond to the third color class. This construction corresponds to the proper edge coloring of  $K_4$  with  $(u_1, u_2)$  and  $(u_3, u_4)$  in the first color class,  $(u_1, u_3)$  and  $(u_2, u_4)$  in the second color class, and  $(u_1, u_4)$  and  $(u_2, u_3)$  in the third color class. Since edge  $(u_1, u_2)$  is in the first color class, the hyperedges in  $\hat{H}$  corresponding to  $e_1$  ( $\hat{e}_{1,1}$  and  $\hat{e}_{1,2}$ ) intersect the hyperedges corresponding to  $e_2$  ( $\hat{e}_{2,1}$  and  $\hat{e}_{2,2}$ ) in vertex subsets  $\hat{V}_{r+1}$  and  $\hat{V}_{r+2}$ . Similarly, since edge  $(u_3, u_4)$  is in the first color class, the hyperedges in  $\hat{H}$  corresponding to  $e_3$  intersect the hyperedges corresponding to  $e_4$  in vertex subsets  $\hat{V}_{r+1}$  and  $\hat{V}_{r+2}$ . Likewise, since edge  $(u_1, u_3)$  is in the second color class, the hyperedges in  $\hat{H}$  corresponding to  $e_1$  intersect the hyperedges corresponding to  $e_3$  in vertex subsets  $\hat{V}_{r+3}$  and  $\hat{V}_{r+4}$ . The remaining three edges in  $K_4$  similarly describe how the hyperedges intersect in  $\hat{H}$  in the newly-added subsets.

Note that a minimum vertex cover for  $H$  is a minimum vertex cover for  $\hat{H}$ . The newly-added vertices cannot be used to create a cover of smaller cardinality. A smaller cardinality cover is not possible because each pair of hyperedges has at most one vertex in common in  $\hat{V}_R$  and we have doubled the number of hyperedges in  $H$  to create  $\hat{H}$ .

## 4 Covering Tornados

In the introduction, we stated that any intersecting hypergraph where  $\tau \neq \nu$  must contain a certain kind of sub-hypergraph, which we call a tornado. In this section, we formally define tornados and prove several bounds on the covering numbers of  $r$ -partite tornados.

**Definition 3.** A *tornado* is an intersecting hypergraph  $H = (V, E)$  where there is a vertex set  $V_{eye}$  with  $|V_{eye}| = |E|$  such that the corresponding  $|E| \times |E|$  submatrix of the incidence matrix is the incidence matrix of a graph that is an odd cycle.

Note every tornado by definition necessarily has an odd number of hyperedges. We call the vertex set  $V_{eye}$  the *eye* of the tornado. We call these hypergraphs “tornados” since they can often be

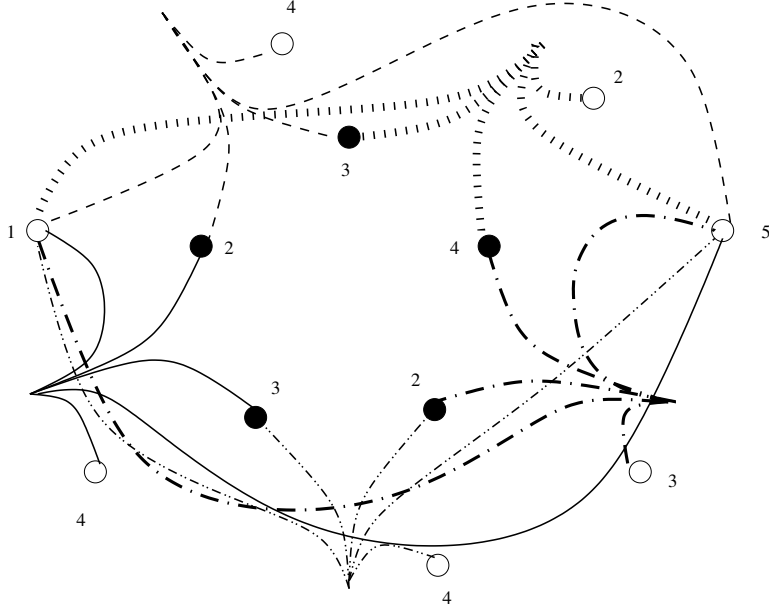

Figure 1: A 5-partite tornado with 5 hyperedges. The black vertices are those in  $V_{eye}$  and the white vertices are in  $V \setminus V_{eye}$ . The label on each vertex denotes which of the five subsets contain the vertex. Each hyperedge has a distinct pattern and all hyperedges intersect at vertices in subsets 1 and 5.

drawn as having part of every hyperedge composing an odd cycle (i.e., the eye) while the remaining parts are “twisted” around the eye. Figure 1 illustrates an example of a tornado. The definition of tornado is reciprocal to Berge’s concept of balanced matrices and hypergraphs [3]: a tornado-free  $r$ -partite intersecting hypergraph is a balanced hypergraph.

We now prove upper bounds for the covering number of tornados. We use the following notation throughout this section: Let  $E = \{e_i : i = 1, \dots, |E|\}$  be the hyperedges of a tornado with  $e_i \cap e_{i+1} \cap V_{eye} = \{v_i\}$  for  $i = 1, \dots, |E| - 1$  and with  $e_{|E|} \cap e_1 \cap V_{eye} = \{v_{|E|}\}$ ; thus,  $V_{eye} = \{v_1, \dots, v_{|E|}\}$ .

First we prove Ryser’s Conjecture is easily resolved for tornados.

**Proposition 4.** *For an  $r$ -partite tornado,  $\tau \leq r - 1$ .*

*Proof.* It suffices to construct a vertex cover  $C$  of an  $r$ -partite tornado that contains at most  $r - 1$  vertices.

Choose an arbitrary hyperedge  $e_1$ .  $e_1$  has  $r - 2$  vertices in  $V \setminus V_{eye}$ , and  $e_1$  intersects each of the hyperedges  $e_3, \dots, e_{|E|-1}$  at a vertex in  $V \setminus V_{eye}$ . Including these  $r - 2$  vertices in  $C$  ensures that every hyperedge is covered except  $e_2$  and  $e_{|E|}$ .

Since every tornado is an intersecting hypergraph,  $e_2$  and  $e_{|E|}$  must intersect at some vertex in

$V \setminus V_{eye}$ . Including this vertex in  $C$  produces a vertex cover with cardinality  $r - 1$ .  $\square$

**Proposition 5.** *For an  $r$ -partite tornado,  $\tau \leq \frac{|E|+1}{2}$ .*

*Proof.* It suffices to construct a vertex cover  $C$  of an  $r$ -partite tornado that contains at most  $\frac{|E|+1}{2}$  vertices. Choosing  $C = \{v_1, v_3, v_5, \dots, v_{|E|}\}$  gives such a cover.  $\square$

The next proposition proves the upper bound from Proposition 5 is tight for tornados where  $|E| \leq 2 \lfloor \frac{r+1}{2} \rfloor - 1$ .

**Proposition 6.** *Given  $r$ , there exist tornados with  $|E| = 3, 5, \dots, 2 \lfloor \frac{r+1}{2} \rfloor - 1$  such that  $\tau = \frac{|E|+1}{2}$ .*

*Proof.* Consider a proper edge coloring of the complete graph  $K_m = (\hat{V}^{m-1} \cup \{\hat{v}_m\}, \hat{E})$  where  $m = 2 \lfloor \frac{r+1}{2} \rfloor$  with  $m - 1$  colors. Such a proper edge coloring exists because  $m$  is even. Construct a hypergraph  $H = (V, E)$  where  $V = \bigcup_{k=1}^{m-1} V_k$  and  $E = \{e_i : i = 1, 2, \dots, |E|\}$  such that there is a bijection between vertices in  $\hat{V}^{m-1}$  and hyperedges in  $E$ .

For each edge  $(\hat{v}_i, \hat{v}_j) \in K_m$  with  $i, j \neq m$  and color  $k$ , create a vertex in  $V_k$  with hyperedges  $e_i$  and  $e_j$  incident to it. For each edge  $(\hat{v}_i, \hat{v}_m) \in K_m$  with color  $k$ , create a vertex in  $V_k$  with only hyperedge  $e_i$  incident to it.

The hypergraph is  $(m - 1)$ -partite because in  $K_m$  every vertex has degree  $m - 1$  and for each edge in  $K_m$  there is a vertex. The hypergraph is intersecting by construction because for any pair of hyperedges there is an edge in  $K_m$ . The hypergraph is a tornado with eye  $\{v_{1,2}, v_{2,3}, \dots, v_{m-2,m-1}, v_{m-1,1}\}$  where  $v_{i,i+1}$  is the unique vertex that is contained in hyperedges  $e_i$  and  $e_{i+1}$ .

A cover for  $H$  is the subset of vertices  $\{v_{i,i+1} : i \text{ odd}\} \cup v_{m-1,1}$ , so  $\tau \leq \frac{|E|+1}{2}$ . This cover is of minimum size because a set of vertices of size  $\frac{|E|-1}{2}$  or less can cover at most  $2 \frac{|E|-1}{2} = |E| - 1$  hyperedges. Therefore,  $H$  is a tornado with  $2 \lfloor \frac{r+1}{2} \rfloor - 1$  hyperedges with  $\tau = \frac{|E|+1}{2}$ . From  $H$  we can construct a tornado with any odd number of hyperedges  $h$  by taking the sub-hypergraph formed by edges  $\{e_i : i = 1, \dots, h\}$  where  $h \geq 3$ .  $\square$

The next proposition proves the upper bound on the covering number for  $r$ -partite tornados can be slightly tighter than that in Proposition 5 if  $|E| > r$ .

**Proposition 7.** *For an  $r$ -partite tornado with  $|E| > r$ ,  $\tau \leq \frac{|E|-1}{2}$ .*

*Proof.* It suffices to construct a vertex cover  $C$  that contains at most  $\frac{|E|-1}{2}$  vertices.

Let  $e_1$  be any hyperedge in the tornado. Then  $e_1$  intersects at least  $|E| - 2$  other hyperedges at vertices that are not in the eye of the tornado, which means these intersections occur in at most  $r - 2$  subsets of the  $r$ -partition of vertices.

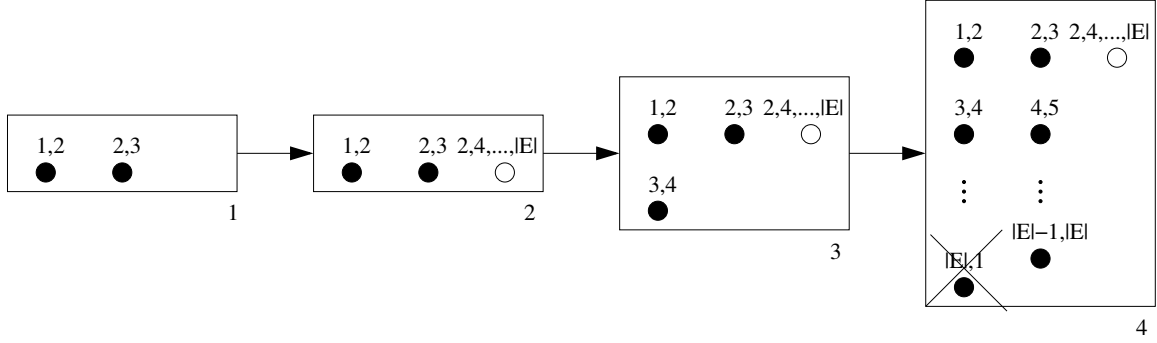

Figure 2: Illustration of a proof of Proposition 9. The black vertices correspond to vertices in  $V_{eye}$ . The labels on the vertices represent the incident hyperedges. Each column of vertices corresponds to a subset of the 3-partition.

If  $|E| > r$ , then  $|E| - 2 > r - 2$ , and there is at least one vertex  $v$  where  $e_1$  intersects two other hyperedges. Place  $v$  in the vertex cover, leaving  $|E| - 3$  hyperedges to be covered. Since  $|E|$  is odd,  $|E| - 3$  is even. There exists a vertex contained in each pair of these hyperedges because the hypergraph is intersecting. Thus, the remaining  $|E| - 3$  hyperedges can be covered with  $\frac{|E|-3}{2}$  vertices, which means we have constructed a vertex cover of size  $\frac{|E|-3}{2} + 1 = \frac{|E|-1}{2}$ .  $\square$

**Corollary 8.** *An  $r$ -partite tornado with  $\tau = r - 1$  and  $r \geq 4$ , if one exists, has at least  $2r - 1$  hyperedges.*

*Proof.* Suppose that an  $r$ -partite tornado with  $\tau = r - 1$  and  $|E| < 2r - 1$  exists. If  $|E| \leq r$ , then by Proposition 5,  $\tau \leq \frac{|E|+1}{2} < r - 1$ , which is a contradiction. Similarly, if  $r < |E| < 2r - 1$ , then by Proposition 7,  $\tau \leq \frac{|E|-1}{2} < r - 1$ , which is a contradiction.  $\square$

**Proposition 9.** *Every 3-partite tornado has exactly 3 hyperedges.*

*Proof.* Suppose that  $H = (V, E)$  is a 3-partite tornado with  $|E| \geq 5$ . Without loss of generality, let  $v_1 \in V_1$  and  $v_2 \in V_2$ . Then  $e_2$  intersects hyperedges  $e_4, \dots, e_{|E|}$  in  $V_3 \cap V \setminus V_{eye}$ , and all of the vertices in  $V_{eye}$  are in  $V_1$  and  $V_2$ . Then  $v_{|E|} \in V_1$ , which means  $e_1$  has two vertices in  $V_1$ , which contradicts the fact that  $H$  is 3-partite. Figure 2 presents a schematic of this proof.  $\square$

We now present the final result of this section.

**Theorem 10.** *For a 4-partite tornado with  $|E| \geq 5$ ,  $\tau = 1$ .*

*Proof.* Suppose, for the sake of contradiction, we are given a 4-partite tornado  $H_T$  with the minimum number of hyperedges with  $\tau \geq 2$  and  $|E| \geq 5$ .

Without loss of generality, let  $v_{|E|} \in V_1$ ,  $v_1 \in V_2$ , and  $v_2 \in V_3$ . We may assume the vertices of  $V_{eye}$  are contained in at least 3 subsets of the 4-partition since otherwise the vertices in  $V_{eye}$  correspond to an odd cycle in a bipartite graph, which is impossible. This setup implies  $e_1$  and  $e_3$  intersect at a vertex in  $V_4 \cap V \setminus V_{eye}$  and  $e_2$  and  $e_{|E|}$  intersect at a vertex in  $V_4 \cap V \setminus V_{eye}$ . Figures 3, 4, and 5 present schematics for the proofs of Cases I, II, and III that follow. We refer to these schematics throughout our proofs.

Case I:  $v_3 \in V_2$ . The first box in Figure 3 illustrates the starting point for Case I.

From this setup, we can infer that the following pairs of hyperedges must intersect at a vertex in  $V_4 \cap V \setminus V_{eye}$ :  $e_1$  and  $e_3$ ,  $e_2$  and  $e_{|E|}$ , and  $e_3$  and  $e_{|E|}$ . Therefore,  $e_1$ ,  $e_2$ ,  $e_3$ , and  $e_{|E|}$  intersect at a single vertex in  $V_4 \cap V \setminus V_{eye}$  (Figure 3, box 2).

If  $|E| = 5$ , then  $v_4 \in V_3$  and  $e_1$  and  $e_4$  intersect at a vertex in  $V_4 \cap V \setminus V_{eye}$ . This means all hyperedges intersect at a single vertex in  $V_4 \cap V \setminus V_{eye}$ , which contradicts our assumption that  $\tau \geq 2$ . Therefore, we may assume  $|E| \geq 7$ . We can remove  $e_1$ ,  $e_2$ , and  $e_3$  and add a new hyperedge  $e_a$  that contains the vertices  $(e_1 \cap (V_1 \cup V_3 \cup V_4)) \cup (e_3 \cap V_2)$ . This creates a 4-partite tornado  $H_{T_a}$  with  $|E| - 2$  hyperedges (Figure 3, box 3).

Since we are assuming  $H_T$  is a 4-partite tornado with the fewest number of hyperedges such that  $\tau \geq 2$ , then we know  $\tau(H_{T_a}) = 1$ . If the minimum vertex cover of  $H_{T_a}$  is comprised of the vertex in  $e_a \cap V_4$ , then that vertex also covers  $H_T$ , which is a contradiction. Therefore, the vertex in  $e_a \cap V_3$  is a cover for  $H_{T_a}$  (Figure 3, box 4).

Moreover, this setup implies  $v_{|E|-1} \in V_2$ . We can remove  $e_a$  and restore hyperedges  $e_1$ ,  $e_2$  and  $e_3$  (Figure 3, box 5).

Now, we can remove hyperedges  $e_{|E|}$ ,  $e_1$ , and  $e_2$  and replace them with  $e_b$ , where  $e_b$  contains the vertices  $(e_2 \cap (V_1 \cup V_3 \cup V_4)) \cup (e_{|E|} \cap V_2)$ . Note this creates another tornado  $H_{T_b}$  that has  $|E| - 2$  hyperedges (Figure 3, box 6).

By our assumption, we know  $\tau(H_{T_b}) = 1$ . If the vertex in  $e_b \cap V_4$  is a cover for  $H_{T_b}$  then it is a cover for  $H_T$ , so the vertex in  $e_b \cap V_1$  must be the cover for  $H_{T_b}$ . This setup is depicted in the seventh box in Figure 3 and the setup where  $e_b$  is removed and  $e_{|E|}$ ,  $e_1$  and  $e_2$  are restored is depicted in the eighth box in Figure 3.

This setup implies  $v_j \in V_2$  for every odd value of  $j$  and  $v_j \in V_4$  for every even value of  $j$ . This implies  $v_{|E|-1} \in V_4$ , which contradicts the fact that  $v_{|E|-1} \in V_2$  (Figure 3, box 9).

Case II:  $v_3 \in V_1$  and  $v_{|E|-1} \in V_2$ . The first box in Figure 4 illustrates the starting point for Case II.

From this setup, we can infer the following pairs of hyperedges must intersect at a vertex in  $V_4 \cap V \setminus V_{eye}$ :  $e_1$  and  $e_3$ ,  $e_2$  and  $e_{|E|}$ , and  $e_3$  and  $e_{|E|}$ . Therefore,  $e_1$ ,  $e_2$ ,  $e_3$ , and  $e_{|E|}$  intersect at a single

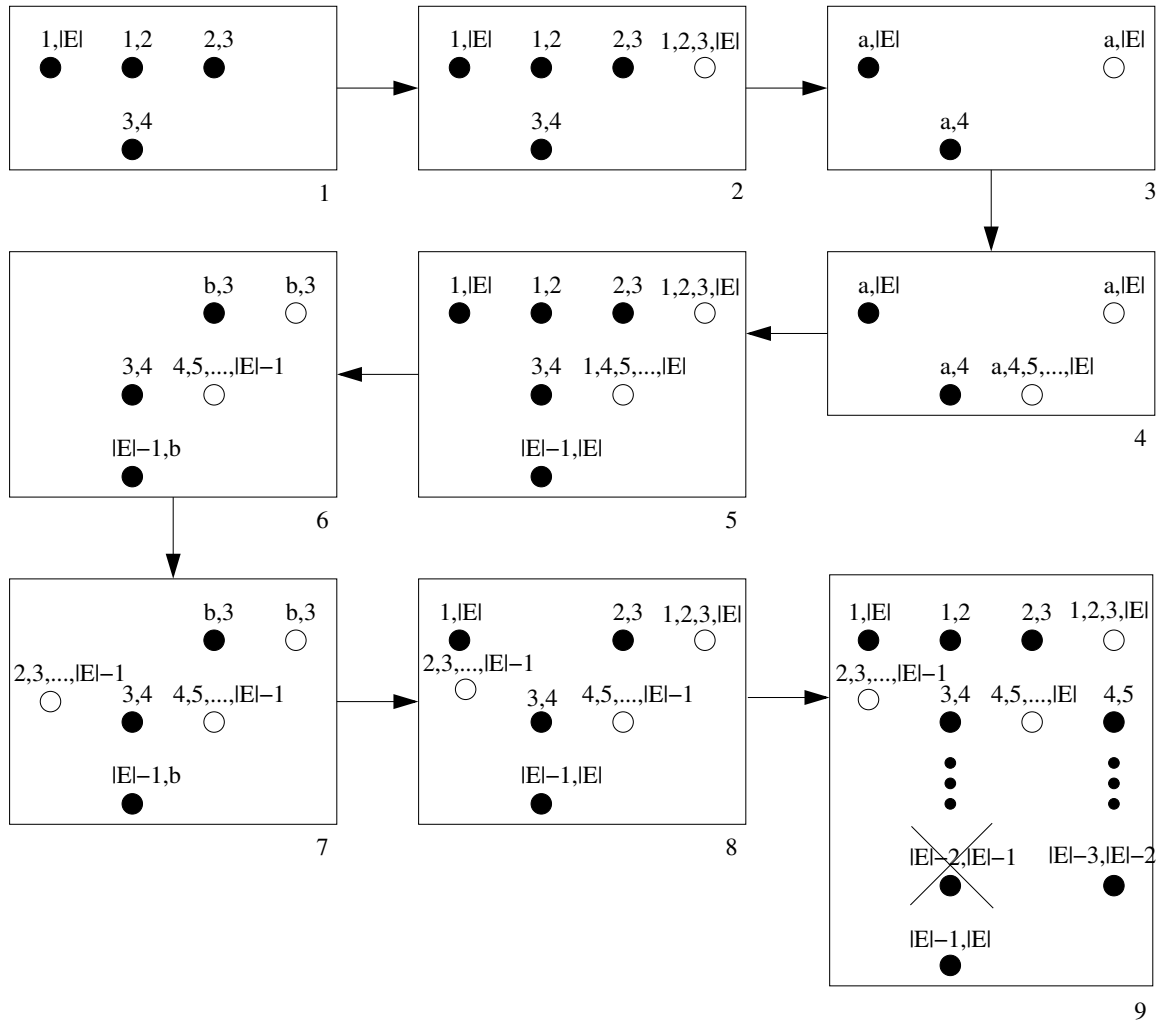

Figure 3: Illustration of a proof of Case I of Theorem 10. The black vertices correspond to vertices in  $V_{eye}$ . The labels on the vertices represent the incident hyperedges. Each column of vertices corresponds to a subset of the 4-partition.

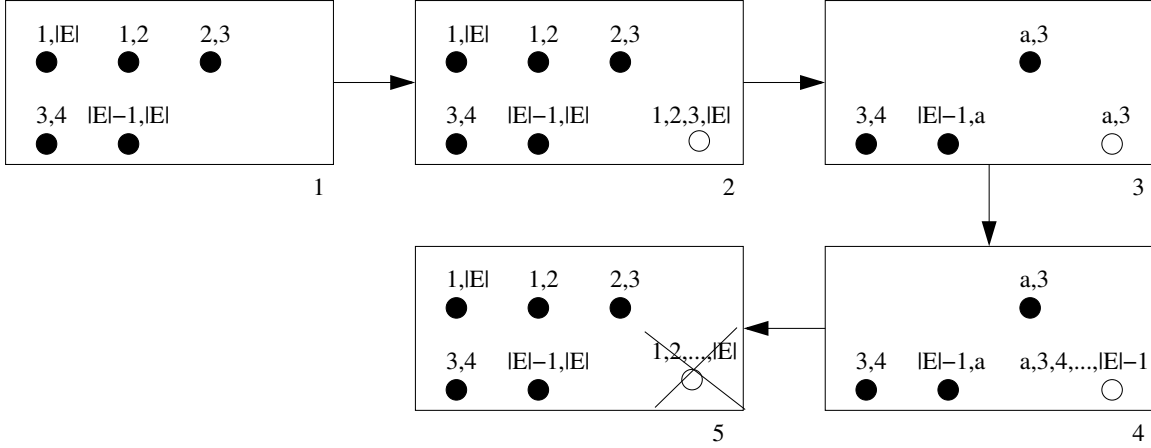

Figure 4: Illustration of a proof of Case II of Theorem 10. The black vertices correspond to vertices in  $V_{eye}$ . The labels on the vertices represent the incident hyperedges. Each column of vertices corresponds to a subset of the 4-partition.

vertex in  $V_4 \cap V \setminus V_{eye}$  (Figure 4, box 2).

If  $|E| = 5$ , then  $e_2$  and  $e_4$  intersect at a vertex in  $V_4 \cap V \setminus V_{eye}$ , which implies all five hyperedges intersect at a single vertex in  $V_4 \cap V \setminus V_{eye}$ , which contradicts our assumption. Thus, we may assume  $|E| \geq 7$ .

We can remove hyperedges  $e_{|E|}$ ,  $e_1$ , and  $e_2$  and replace them with a hyperedge  $e_a$  that contains vertices  $(e_2 \cap (V_1 \cup V_3 \cup V_4)) \cup (e_{|E|} \cap V_2)$ . Note this creates a 4-partite tornado  $H_{T_a}$  that has  $|E| - 2$  hyperedges (Figure 4, box 3).

We know  $\tau(H_{T_a}) = 1$  since we assumed  $H_T$  is a 4-partite tornado with  $\tau(H_T) \geq 2$  that has the fewest number of hyperedges. The unique vertex in the minimum vertex cover for  $H_{T_a}$  must be in  $V_4$  since the vertices in  $V_{eye}$  ensure this vertex cannot be in the other three vertex subsets. Specifically, the vertex that covers  $H_{T_a}$  must be the same vertex in  $V_4$  that is contained in hyperedges  $e_a$  and  $e_3$  (Figure 4, box 4).

After removing  $e_a$  and restoring hyperedges  $e_{|E|}$ ,  $e_1$ , and  $e_2$ , we note these three hyperedges are also incident to the vertex that covers  $H_{T_a}$ , which means this vertex also covers  $H_T$ . However, this is a contradiction since we assumed  $\tau(H_T) \geq 2$  (Figure 4, box 5).

Case III:  $v_3 \in V_1$  and  $v_{|E|-1} \in V_3$ . The first box in Figure 5 illustrates the starting point for Case III.

This setup implies the following pairs of hyperedges must intersect at a vertex in  $V_4 \cap V \setminus V_{eye}$ :  $e_1$  and  $e_3$ ,  $e_2$  and  $e_4$ , and  $e_2$  and  $e_{|E|}$  (Figure 5, box 2).

If  $|E| = 5$ , then  $e_1$  and  $e_4$  intersect at a vertex in  $V_4 \cap V \setminus V_{eye}$ , which implies all hyperedges intersect at a single vertex in  $V_4 \cap V \setminus V_{eye}$ . Thus, we may assume  $|E| \geq 7$ .

If  $v_4 \in V_3$ , then we can remove hyperedges  $e_2$ ,  $e_3$ , and  $e_4$ , replace them with a hyperedge  $e_a$  that contains the vertices  $(e_2 \cap (V_1 \cup V_3 \cup V_4)) \cup (e_4 \cap V_3)$ . This creates a 4-partite tornado  $H_{T_a}$  that has  $|E| - 2$  hyperedges. We know  $\tau(H_{T_a}) = 1$  since we assumed  $H_T$  is a 4-partite tornado with  $\tau(H_T) \geq 2$  that has the fewest number of hyperedges. Specifically, the vertex that covers  $H_{T_a}$  can only be in  $V_4$ . However, this vertex would also be a cover for  $H_T$ , which is a contradiction. Thus, we see  $v_4 \notin V_3$  and we can conclude  $v_4 \in V_2$  (Figure 5, box 3).

Then the following pairs of hyperedges intersect at the same vertex in  $V_4 \cap V \setminus V_{eye}$ :  $e_3$  and  $e_5$ ,  $e_5$  and  $e_{|E|}$ , and  $e_{|E|-1}$  and  $e_4$ . Thus,  $e_1$ ,  $e_2$ ,  $e_3$ ,  $e_4$ ,  $e_5$ ,  $e_{|E|-1}$ , and  $e_{|E|}$  intersect at the same vertex  $v^* \in V_4 \cap V \setminus V_{eye}$  (Figure 5, box 4).

If  $|E| = 7$ , then all hyperedges intersect at  $v^*$ , which is a contradiction. We now prove by induction on the number of remaining vertices in  $V_{eye}$  that all hyperedges intersect at  $v^*$  for tornados with  $|E| > 7$ .

Assume  $v_{i-1} \in (V_1 \cup V_2 \cup V_3)$  for each  $i \in \{|E|, 1, 2, \dots, j-1\}$  and that hyperedges  $e_{|E|-1}, e_{|E|}, e_1, \dots, e_{j-1}$  all intersect at the same vertex  $v^*$  in  $V_4 \cap V \setminus V_{eye}$  (Figure 5, box 5). We now show this implies  $v_{j-1} \in (V_1 \cup V_2 \cup V_3)$  and  $e_j$  also contains  $v^*$ .

First, note that hyperedges  $v_{j-1} \notin V_4$  because this contradicts the fact that  $e_{j-1}$  already contains vertex  $v^* \in V_4 \cap V \setminus V_{eye}$ . Furthermore, note that if

1.  $v_{j-1} \in V_1$ , then  $e_2$  intersects  $e_j$  at a vertex in  $V_4 \cap V \setminus V_{eye}$ , which can only occur at  $v^*$ .
2.  $v_{j-1} \in V_2$ , then  $e_3$  intersects  $e_j$  at a vertex in  $V_4 \cap V \setminus V_{eye}$ , which can only occur at  $v^*$ .
3.  $v_{j-1} \in V_3$ , then  $e_1$  intersects  $e_j$  at a vertex in  $V_4 \cap V \setminus V_{eye}$ , which can only occur at  $v^*$ .

These three possibilities are depicted in the sixth box of Figure 5. Thus, in any case,  $e_j$  contains  $v^*$  (Figure 5, box 7), and  $v^*$  is a cover for the tornado (Figure 5, box 8), which is a contradiction. □

## 5 Integrality Gap for an $r$ -Dimensional Matching Formulation

In this section, we provide a proof that the integrality gap of the standard ILP formulation of rDM is exactly  $r - 1$  when  $r - 1$  equals a prime power. Whereas the results of previous sections are concerned with intersecting hypergraphs, the main result of this section applies to the general rDM



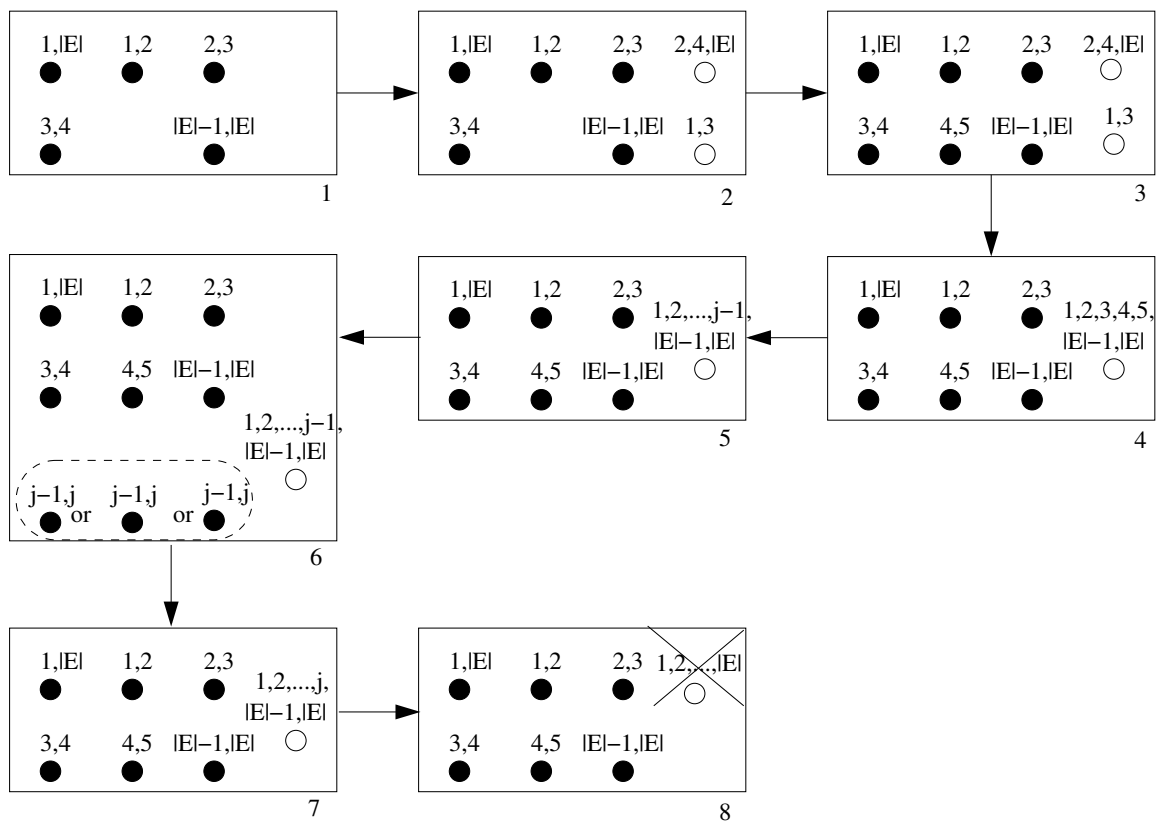

Figure 5: Illustration of a proof of Case III of Theorem 10. The black vertices correspond to vertices in  $V_{eye}$ . The labels on the vertices represent the incident hyperedges. Each column of vertices corresponds to a subset of the 4-partition.

problem. Other researchers, such as Mansour et al. [12], have proven the lower bound on integrality gap using projective planes. Our proof of the lower bound is an equivalent construction that uses MOLS. There is a known correspondence between projective planes of order  $r$  and a complete set of  $r - 1$   $r$ -dimensional MOLS [1]. We use Füredi's Theorem to prove the upper bound on the integrality gap. In addition, we extend the result to show the integrality gap is at least  $r - k$  where  $k$  is the smallest positive integer such that  $r - k$  is a prime power.

Let  $x_e$  equal 1 if hyperedge  $e$  is in our matching and 0 otherwise. The standard ILP for rDM is the following:

**Integer linear programming formulation of rDM (rDM-ILP):**

$$\text{Maximize } \sum_{e \in E} x_e,$$

Subject to

$$\sum_{e \in E: v \in e} x_e \leq 1 \quad \forall v \in V,$$

$$x_e \in \{0, 1\} \quad \forall e \in E.$$

The LP relaxation of rDM-ILP is the ILP except with the binary constraints replaced by non-negativity constraints. The LP relaxation of rDM-ILP shall henceforth be abbreviated as rDM-LP. Note that we need not constrain each of the LP decision variables to be less than or equal to 1, since these constraints are implied by the matching constraints.

**Lemma 11.** *The integrality gap of rDM-ILP is at most  $r - 1$ .*

*Proof.* Let  $I$  be any instance of rDM so that  $\nu$  is the objective value of an optimal solution to the instance as formulated by rDM-ILP. Since the underlying hypergraph of any instance of rDM is  $r$ -partite, we know from Füredi's Theorem that we can construct a fractional vertex cover  $C_f$  with a cardinality of  $(r - 1)\nu$ . Note that such a cover is a feasible solution to the dual of rDM-LP and has an objective value of  $(r - 1)\nu$ . Thus, by duality theory, we know the objective value of an optimal solution to rDM-ILP of  $I$  is bounded above by  $(r - 1)\nu$ .  $\square$

To prove that the integrality gap of rDM-ILP is at least  $r - 1$  whenever  $r - 1$  is a prime power, it suffices to construct a family of instances where the optimal objective value to rDM-ILP is  $z_r^*$  and the optimal objective value to rDM-LP is at least  $(r - 1)z_r^*$ .

Theorem 2 provides that for any prime power  $r - 1$ , there exists a set of  $r - 2$  MOLS  $L_1, L_2, \dots, L_{r-2}$ , each of which have dimension  $r - 1$ . We use this set of MOLS to construct an instance of rDM. In addition, define  $L_{r-1}$  to be the square matrix of dimension  $r - 1$  where every entry in row  $i$  is the number  $i$ , for each  $i$  in  $\{1, 2, \dots, r - 1\}$ . (Note  $L_{r-1}$  is not a Latin square.)

From  $\mathcal{L} = \{L_i : i = 1, \dots, r-1\}$  construct an  $r$ -partite hypergraph  $H_r = (\bigcup_{j=1}^r V_j, E)$  as follows:

1. Let each subset  $V_1, V_2, \dots, V_r$  contain  $r-1$  vertices. Let  $v_{i,j}$  be the  $i$ th vertex in subset  $V_j$ .
2. For each  $k$  and for each element  $a$  contained in matrix  $L_k$ , create a hyperedge  $e_a$  that contains the vertex  $v_{k,r}$  and the vertex  $v_{i,j}$  for each pair  $(i, j)$  such that  $L_k(i, j) = a$ .

**Example Construction:** For illustrative purposes, we describe how our method constructs  $H_r$  for the case when  $r = 4$ . First, we construct two MOLS of size 3:

$$L_1 = \begin{bmatrix} 1 & 2 & 3 \\ 2 & 3 & 1 \\ 3 & 1 & 2 \end{bmatrix} \quad L_2 = \begin{bmatrix} 1 & 3 & 2 \\ 2 & 1 & 3 \\ 3 & 2 & 1 \end{bmatrix}$$

Next, we construct the matrix  $L_3$ :

$$L_3 = \begin{bmatrix} 1 & 1 & 1 \\ 2 & 2 & 2 \\ 3 & 3 & 3 \end{bmatrix}$$

This allows us to construct  $H_4 = (\bigcup_{j=1}^4 V_j, E)$  where  $V_j = \{v_{1,j}, v_{2,j}, v_{3,j}\}$  for each  $j$  in  $\{1, 2, 3, 4\}$  and

$$E = \left\{ \begin{array}{l} (v_{1,1}, v_{3,2}, v_{2,3}, v_{1,4}), \quad (v_{2,1}, v_{1,2}, v_{3,3}, v_{1,4}), \quad (v_{3,1}, v_{2,2}, v_{1,3}, v_{1,4}), \\ (v_{1,1}, v_{2,2}, v_{3,3}, v_{2,4}), \quad (v_{2,1}, v_{3,2}, v_{1,3}, v_{2,4}), \quad (v_{3,1}, v_{1,2}, v_{2,3}, v_{2,4}), \\ (v_{1,1}, v_{1,2}, v_{1,3}, v_{3,4}), \quad (v_{2,1}, v_{2,2}, v_{2,3}, v_{3,4}), \quad (v_{3,1}, v_{3,2}, v_{3,3}, v_{3,4}) \end{array} \right\}.$$

We now prove several properties about  $H_r$ .

**Lemma 12.**  *$H_r$  is an intersecting hypergraph.*

*Proof.* Note that any hyperedge in  $H_r$  is created using one matrix in  $\mathcal{L}$ . Any two hyperedges created using the same matrix in  $\mathcal{L}$  intersect because they both contain the same vertex from  $V_r$ .

Now consider two hyperedges  $e_a$  and  $e_b$  that are created from two distinct matrices  $L_a$  and  $L_b$ . Let  $L_{a,b}$  be the paired matrix that results from pairing  $L_a$  with  $L_b$ .

Every hyperedge created using  $L_a$  intersects every hyperedge created using  $L_b$  if  $L_{a,b}$  contains every ordered pair from the set  $[r-1] \times [r-1]$ . First, consider the case when  $a = r-1$ . For each element  $i$  in  $[r-1]$ , every element in row  $i$  from  $L_a$  is the number  $i$  since  $L_a = L_{r-1}$ . Similarly, every element

from  $[r - 1]$  appears in exactly one entry in row  $i$  of  $L_b$  since  $L_b$  is a Latin square. Thus, for each  $i$  in  $[r - 1]$ , row  $i$  in  $L_{a,b}$  contains  $(i, j)$  for each  $j$  in  $[r - 1]$ . Therefore, every hyperedge created using  $L_a$  intersects every hyperedge that is created using  $L_b$ . The same argument applies for the case when  $b = r - 1$ .

Now consider the case where  $a \neq r - 1$  and  $b \neq r - 1$ . This means both  $L_a$  and  $L_b$  are MOLS, which means that their paired matrix contains  $(i, j)$  exactly once, for each  $(i, j)$  in  $[r - 1] \times [r - 1]$ . Therefore, in this case every hyperedge created using  $L_a$  intersects with every hyperedge created using  $L_b$ .  $\square$

**Lemma 13.** *The optimal objective value to rDM-LP for  $H_r$  is at least  $r - 1$ .*

*Proof.* To prove this lemma, we construct a feasible solution to rDM-LP that has objective value  $r - 1$ . Specifically, set  $x_e = \frac{1}{r-1}$  for each  $e \in E$ .

For each vertex  $v \in \bigcup_{j=1}^r V_j$ , the corresponding constraint is satisfied because each vertex has a degree of  $r - 1$ . This holds because for each vertex there is one hyperedge created using each matrix in  $\mathcal{L}$  and  $|\mathcal{L}| = r - 1$ . Thus, this solution is feasible.

In addition, there are  $(r - 1)^2$  hyperedges in  $H_r$  since each matrix in  $\mathcal{L}$  is used to create  $r - 1$  hyperedges and  $|\mathcal{L}| = r - 1$ . Thus, the objective value of this solution is  $\frac{(r-1)^2}{(r-1)} = r - 1$ .  $\square$

**Theorem 14.** *The integrality gap of rDM-ILP when  $r - 1$  is a prime power is exactly  $r - 1$ .*

*Proof.* By Lemma 11, the integrality gap of rDM-ILP is at most  $r - 1$ . By Lemma 12,  $H_r$  is intersecting and has matching number 1, so that the optimal objective value of rDM-ILP is 1. By Lemma 13, the objective value of rDM-LP is at least  $r - 1$ . Therefore, the integrality gap for instances  $H_r$  is exactly  $r - 1$ .  $\square$

**Corollary 15.** *The integrality gap of rDM-ILP is at least  $r - k$  where  $k$  is the smallest positive integer such that  $r - k$  is a prime power.*

*Proof.* Assume  $k > 1$  since the case when  $k = 1$  is handled by Theorem 14. Since  $r - k$  is a prime power, the hypergraph  $H_{r-k+1}$  that is defined using the aforementioned construction exists. This hypergraph is  $(r - k + 1)$ -partite and each subset of the partition contains  $r - k + 1$  vertices. Construct an  $r$ -partite hypergraph  $\tilde{H}_r$  from  $H_{r-k+1}$  as follows.

For each vertex in  $H_{r-k+1}$ , create a corresponding vertex in  $\tilde{H}_r$ .

In addition, create  $r - k + 1$  vertices  $v_{i,r-k+2}, v_{i,r-k+3}, \dots, v_{i,r}$  for each  $i \in \{r - k + 2, r - k + 3, \dots, r\}$  where  $v_{i,r-j} \in V_j$  for each  $j \in \{r - k + 2, r - k + 3, \dots, r\}$ . Lastly, for each hyperedge  $e =$

$(v_{i,j}, \dots, v_{\ell, r-k+1})$  in  $H_{r-k+1}$  create the hyperedge  $\tilde{e} = (v_{i,j}, \dots, v_{\ell, r-k+1}, v_{\ell, r-k+2}, v_{\ell, r-k+3}, \dots, v_{\ell, r})$  in hypergraph  $\tilde{H}_r$ .

$\tilde{H}_r$  has a maximum cardinality matching of exactly one hyperedge since it is an intersecting hypergraph. We can obtain a solution to rDM-LP with objective value  $r - k$  by setting  $x_e = \frac{1}{r-k}$  for each hyperedge  $e$  in  $\tilde{H}_r$ .  $\square$

## 6 Conclusions and Future Work

In this paper, we use ideas common in the math programming community to gain further insight into two well-studied combinatorics problems. First, we show that the  $r$ -Dimensional Vertex Cover Problem is NP-hard for intersecting hypergraphs. This result is interesting because the  $r$ -Dimensional Matching Problem is trivial for intersecting hypergraphs. The construction in our proof uses a well-known algorithm for obtaining a proper edge coloring in a complete graph (which is also a well-known algorithm for scheduling a single round-robin tournament).

We note that Ryser’s conjecture is easily resolved for intersecting hypergraphs that do not contain a sub-hypergraph that we call a tornado. A tornado-free intersecting hypergraph can be covered with a single vertex. We prove several bounds on the covering number of tornados. Extending these results to a possible proof of Ryser’s conjecture for intersecting hypergraphs would involve characterizing how tornados can be arranged in a hypergraph.

We demonstrate an equivalence between two previous results and the integrality gap for the  $r$ -Dimensional Matching Problem. We then extend the result to provide a bound for any value of  $r$ , whereas the previous result only provides bounds for the case when  $r - 1$  is a prime power.

## 7 Acknowledgments

The first author is supported in part by the Office of Naval Research. The second author is supported in part by NASA award NNX09AR44A.

## References

- [1] R.J.R. Abel, C. Colbourn, and J. Dinitz, “Mutually orthogonal latin squares(MOLS),” Handbook of Combinatorial Designs, 2nd edition, C.J. Colbourn and J.H. Dinitz (Editors), Chapman & Hall/CRC, Boca Raton, Florida, 2006, pp. 160–193.

- [2] R. Aharoni, Ryser’s conjecture for tripartite 3-graphs, *Combinatorica* 21 (2001), 1–4.
- [3] C. Berge, Balanced matrices, *Math Program* 2 (1972), 19–31.
- [4] Y.H. Chan and L.C. Lau, On linear and semidefinite programming relaxations for hypergraph matching, *Proc Twenty-First Ann ACM-SIAM Symp on Discrete Algorithms*, Austin, TX, 2010, pp. 1500–1511.
- [5] Z. Füredi, Maximum degree and fractional matchings in uniform hypergraphs, *Combinatorica* 1 (1981), 155–162.
- [6] G. Gottlob and P. Senellart, Schema mapping discovery from data instances, *J ACM* 57 (2010), DOI: 10.1145/1667053.1667055.
- [7] R.M. Karp, “Reducibility among combinatorial problems,” *Complexity of Computer Computations*, R.E. Miller and J.W. Thatcher (Editors), Plenum, New York, 1972, pp. 85–103.
- [8] D. Kőnig, Gráfok és mátrixok, *Matematikai és Fizikai Lapok* 38 (1931), 116–119.
- [9] T. Kirkman, On a problem in combinatorics, *Cambridge Dublin Math J* 2 (1847), 191–204.
- [10] L. Lovász, On minimax theorems of combinatorics, *Matemathikai Lapok* 26 (1975), 209–264.
- [11] L. Lovász, On the ratio of optimal integral and fractional covers, *Discr Math* 13 (1975), 383–390.
- [12] T. Mansour, C. Song, and R. Yuster, A comment on Ryser’s conjecture for intersecting hypergraphs, *Graphs Combin* 25 (2009), 101–109.
- [13] Z. Tuza, Ryser’s conjecture on transversals of  $r$ -partite hypergraphs, *Ars Combin* 16 (1983), 201–209.
- [14] D.B. West, *Introduction to graph theory*, Pearson Education, Urbana, Illinois, 2001.