



VCU

Virginia Commonwealth University
VCU Scholars Compass

Theses and Dissertations

Graduate School

2017

A comparative analysis of geometric morphometrics across two *Pseudemys* turtle species in east central Virginia

Kristin C. Dillard
Virginia Commonwealth University

Follow this and additional works at: <https://scholarscompass.vcu.edu/etd>



Part of the [Biodiversity Commons](#), [Population Biology Commons](#), and the [Zoology Commons](#)

© The Author

Downloaded from

<https://scholarscompass.vcu.edu/etd/4917>

This Thesis is brought to you for free and open access by the Graduate School at VCU Scholars Compass. It has been accepted for inclusion in Theses and Dissertations by an authorized administrator of VCU Scholars Compass. For more information, please contact libcompass@vcu.edu.

© Kristin Dillard 2017

All rights reserved.

A comparative analysis of geometric morphometrics across two *Pseudemys* turtle species in east central Virginia

A thesis submitted in partial fulfillment of the requirements for the degree of Master of Science
at Virginia Commonwealth University.

by

Kristin Cline Dillard, Bachelor of Arts, College of William and Mary
Director: Dr. Rodney Dyer, Director, Center for Environmental Studies

Virginia Commonwealth University

Richmond, Virginia

May 2017

Acknowledgements

I wish to express my sincere thanks and indebtedness to my committee for their invaluable insight and direction from the beginning of this project. I would also like to thank my parents, Hope and Robert Dillard, for their enthusiastic and often relentless encouragement over the duration of this project. Benjamin Colteaux also deserves earnest thanks and recognition, for without his sharp inquisitiveness and keen perception, this project would never have been undertaken. Most of all, I wish to express my most heartfelt appreciation and gratitude to the staff at the Smithsonian Museum Support Center's Division of Amphibians and Reptiles, especially to Jeremy Jacobs, Wynn Addison and Kenneth Tighe, without whose indispensable guidance and assistance, this study would not have been possible.

This publication was completed with funds provided by the Virginia Department of Game and Inland Fisheries through a State Wildlife Grant from the U.S. Fish and Wildlife Service (2012-13651) as part of a larger study assessing the viability of Virginia snapping turtle populations under increasing harvest pressure. Animal experiments were conducted in the field under the research protocol IACUC AD10000461, which was approved by the Virginia Commonwealth University Institutional Animal Care and Use Committee (IACUC) in accordance with the USDA Animal Welfare Regulations; the Public Health Service Policy on the Humane Care and Use of Laboratory Animals; and The United States Government Principles for the Utilization and Care of Vertebrate Animals Used in Testing, Research, and Training. Virginia Commonwealth University is in compliance with all provisions of the Animal Welfare Act and

other federal statutes and regulations relating to animals. Virginia Commonwealth University is registered under the Animal Welfare Act as a Class “R” Research Facility with the USDA-APHIS-Animal Care (Registration number: 52-R-0007).

Table of Contents

	Page
List of Tables	vi
List of Figures	viii
Abstract	xii
1 Introduction	1
2 Methods and Analysis	7
2.1 Species Identification	7
2.2 Study Sites	8
2.3 Data collection	9
2.4 Measurement-based morphometric data	10
2.5 Landmark-based geometric morphometrics: plastron shape data	11
2.6 Landmark-based geometric morphometrics: upper jaw shape data	12
3 Results	13
3.1 Trait-based morphological analysis	13
3.2. Measurement-based morphological analysis	13
3.3. Landmark-based morphological analysis	14

4 Discussion	17
References	21
Tables	28
Figures	37

List of Tables

	Page
Table 1. Indicator traits found in thirteen field-collected specimens. Where the trait is consistent with eastern river cooters, the trait is assigned “ERC”. Where the trait is consistent with northern red bellied cooters, the trait is assigned “RBC”. Where the trait is indiscernible using field photography, the trait is listed as N/A (not available).	13
Table 2. Summary of plastron length to carapace length ratio data for MV eastern river cooters, MV northern red bellied cooters, and field-caught <i>Pseudemys</i> specimens.	14
Table 3. Summary of ANOVA for plastron length to carapace length ratios for MV eastern river cooters, MV northern red bellied cooters, and field-caught <i>Pseudemys</i> specimens.	14
Table 4. Summary of one-way ANOVA for shell height ratios for MV eastern river cooters, MV northern red bellied cooters, and field-caught <i>Pseudemys</i> specimens; data taken for male specimens only.	14
Table 5. Summary of shell height ratio data for MV eastern river cooters, MV northern red bellied cooters, and field-caught <i>Pseudemys</i> specimens; data taken for male specimens only.	14
Table 6. Estimates of eigenvalues and percentage accumulated variation associated with principal components of plastral scute shape landmark data.	14
Table 7. Confusion matrix analyzing the precision of MorphoJ’s classification analysis of plastral shape data for MV eastern river cooters and MV northern red bellied cooters.	15

Table 8. Estimates of eigenvalues and percentage accumulated variation associated with principal components of jaw shape landmark data.	16
Table 9. Confusion matrix analyzing the precision of MorphoJ's classification analysis of plastral shape data for MV eastern river cooters and MV northern red bellied cooters.	16

List of Figures

	Page
Figure 1. Double-cusped upper-jaw, characteristic of the northern red bellied cooter and other red bellied cooters.	4
Figure 2. Absence of cusps on the upper jaw, characteristic of the eastern river cooter.	4
Figure 3. Map of known ranges of the eastern river cooter and northern red bellied cooter in the Commonwealth of Virginia. Redrawn from data collected from the IUCN Red List of Threatened Species (van Dijk, 2016).	7
Figure 4. Typical carapacial scute pattern of both Eastern river and northern red bellied cooters, where M = marginal scute, P = pleural scute, and V = vertebral scute.	7
Figure 5. Prefrontal arrow-shaped marking, characteristic of the northern red bellied cooter.	7
Figure 6. Forked vertical stripes on the carapace and marginal scutes, characteristic of the northern red bellied cooter.	7
Figure 7. Whorling concentric circles on the carapace and backwards-facing C-shaped marking on the second pleural scute, characteristic of the eastern river cooter. Image drawn from photography provided by Pierson Hill.	7
Figure 8. Donut-shaped markings on the underside of the marginal scutes, characteristic of the eastern river cooter.	8

Figure 9. Map of eastern Virginia showing all three riverine study sites chosen for sampling of <i>Pseudemys</i> specimens. Study sites are denoted with hollow circles and labeled in italics, while major cities are denoted with solid circles.	8
Figure 10. Diagram of physical measurements taken from all analyzed <i>Pseudemys</i> specimens.	9
Figure 11. Ventral view of a <i>Pseudemys</i> specimen showing anatomical landmarks used in morphological analysis of the plastron. These landmarks include the intersections of the lines delineating the gular, humeral, pectoral, abdominal, femoral and anal scutes, as well as the local minima of the curve defining the anal scute.	11
Figure 12. Generalized Procrustes superimposition showing average plastron shape of all <i>Pseudemys</i> specimens sampled, with scute types labeled.	11
Figure 13. Head-on view of a northern red bellied cooter showing anatomical landmarks used in morphological analysis of the upper jaw. These landmarks include the palpebra inferior, the local minima of the curve of the upper jaw just below the palpebra inferior, two local maxima and one local minima of the curve delineating the jaw line, the and the midpoint of the septum.	12
Figure 14. Generalized Procrustes superimposition showing average shape of the upper jaw of all <i>Pseudemys</i> specimens sampled.	12
Figure 15. Wireframe graph showing the average plastron shape (as defined by generalized Procrustes superimposition) in black, and the plastron shape defined by principal component 1 in grey.	14
Figure 16. Wireframe graph showing the average plastron shape (as defined by generalized Procrustes superimposition) in black, and the plastron shape defined by principal component 2 in grey.	14

- Figure 17. Scatterplot of the first two principal component axes based on analysis of plastral scute landmarks of all MV specimens, comprising 43% of total variance. MV eastern river cooters are represented by hollow squares, and MV northern red bellied cooters are represented by solid triangles. 15
- Figure 18. Histogram of the observations of plastral scute shape data for MV eastern river cooters and northern red bellied cooters. Group C represents data for eastern river cooters and group R represents northern red bellied cooters. 15
- Figure 19. Plot of plastron shape data of all applicable specimens based on principal components one and two, comprising 43% of total variance. MV eastern river cooters are represented by hollow squares, MV northern red bellied cooters are represented by solid triangles, field-collected specimens represented by hollow circles, and apparent hybrid specimens are represented by asterisks. 15
- Figure 20. Histogram of the observations of plastral scute shape data in each group on the first linear discriminant dimension, achieving 64% separation. Group C represents data for eastern river cooters, group F represents field-collected specimens, and group R represents northern red bellied cooters. 15
- Figure 21. Histogram of the observations of plastral scute shape data in each group on the second linear discriminant dimension, achieving 36% separation. Group C represents data for eastern river cooters, group F represents field-collected specimens, and group R represents northern red bellied cooters. 15
- Figure 22. Plot of the observations of plastral scute shape data of each group in the space of the first two linear discriminant functions, with MV eastern river cooters represented by hollow squares, MV northern red bellied cooters represented by solid triangles, and field-collected specimens represented by hollow circles. 15
- Figure 23. Wireframe graph showing the average jaw shape (as defined by generalized Procrustes superimposition) in black, and the plastron shape defined by principal component 1 in grey. 16

Figure 24. Wireframe graph showing the average jaw shape (as defined by generalized Procrustes superimposition) in black, and the plastron shape defined by principal component 2 in grey. 16

Figure 25. Plot of jaw shape data of MV specimens based on principal components one and two, comprising 72% of total variance. MV eastern river cooters are represented by hollow squares, and MV northern red bellied cooters are represented by solid triangles. 16

Figure 26. Histogram of the observations of jaw shape data for MV eastern river cooters and northern red bellied cooters. Group C represents data for eastern river cooters and group R represents northern red bellied cooters. 16

Figure 27. Plot of jaw shape data of all applicable specimens based on principal components one and two, comprising 72% of total variance. MV eastern river cooters are represented by hollow squares, MV northern red bellied cooters are represented by solid triangles, field-collected specimens represented by hollow circles, and apparent hybrid specimens are represented by asterisks. 16

Figure 28. Histogram of the observations of jaw shape data in each group on the first linear discriminant dimension, achieving 78% separation. Group C represents data for eastern river cooters, group F represents field-collected specimens, and group R represents northern red bellied cooters. 16

Figure 29. Histogram of the observations of jaw shape data in each group on the second linear discriminant dimension, achieving 22% separation. Group C represents data for eastern river cooters, group F represents field-collected specimens, and group R represents northern red bellied cooters. 16

Figure 30. Plot of the observations of jaw shape data of each group in the space of the first two linear discriminant functions, with MV eastern river cooters represented by hollow squares, MV northern red bellied cooters represented by solid triangles, and field-collected specimens represented by hollow circles. 16

Abstract

A COMPARATIVE ANALYSIS OF GEOMETRIC MORPHOMETRICS ACROSS TWO PSEUDEMYNS TURTLE SPECIES IN EAST CENTRAL VIRGINIA

By Kristin Cline Dillard

A thesis submitted in partial fulfillment of the requirements for the degree of Master of Science at Virginia Commonwealth University.

Virginia Commonwealth University, 2017.

Major Advisor: Dr. Rodney Dyer, Director, Center for Environmental Studies

The phylogeny of the turtle genus *Pseudemys* is poorly understood. In Virginia, many turtles have been found with indicator traits of both eastern river cooters (*Pseudemys concinna concinna*) and northern red bellied cooters (*Pseudemys rubriventris*). This study explores morphological evidence for hybridization between the two species across three riverine sites in east central Virginia.

Museum voucher groups for each species were analyzed for relative shell height and plastron length. The shape of the plastral scutes and upper jaw were analyzed using landmark-based morphometric software. These metrics were compared with measurements taken from 188 field-caught *Pseudemys* specimens. Across phenotypic metrics, field specimens resembled northern red bellied cooters. Geometric morphometric analysis showed extreme variation.

Thirteen field specimens exhibited indicator traits of both species. Because species boundaries do not appear to be well-resolved using accepted phenotypes and morphometrics, we suggest that additional research utilizing molecular methods and genetic analysis be conducted.

1. Introduction

The classical model of evolution by speciation is often presented using a scenario in which generations of descendants from a common ancestor gradually diverge from their parent species and contemporary relatives until reproductive isolation is achieved (Mayr 1942, Barton 2001, Coyne and Orr 2004). Because it is based only on divergently branching phylogenetic patterns, this cladistic model is confounded by the presence of hybrids, and fails to produce the correct phylogeny when hybrid specimens are included (Xu 2000). Instead, such models often show evidence of incomplete lineage sorting (Kubatko 2009). However, hybridization was not thought to contribute significantly to animal evolution until recently. As molecular technology has become more accessible, it has become clear that hybridization in the natural world is a widespread and commonly observed phenomenon with recognizable evolutionary consequences ranging from complete inviability of hybrid specimens to the development of novel traits and lineages, which may eventually lead to speciation (Xu 2000, Zinner et al. 2011, Saetre 2013, Vega et al. 2013, Abbott et al. 2013, Martin et al. 2014). However, hybridization is commonly acknowledged as causing deleterious effects on threatened or endangered taxa, especially when the hybridization is the result of the sudden introduction of invasive species (Hegarty 2012, Guo 2014, Söderquist et al. 2014).

Not all hybridization events are ecologically destructive, however. In a highly controversial effort to rescue a small, isolated population of Florida panthers (*Puma concolor coryi*) from fatal genetic bottlenecking, researchers released eight female Texas pumas (*P. c.*

stanleyana) into the Florida panthers' diminutive habitat (Hostetler et al. 2012). The resultant hybrid kittens were three times as likely to reach adulthood as the purebred Florida panthers. Subsequently, the range of the Florida panther increased, and its population rose from around 30 individuals when the Texas pumas were first released in the mid-1990s to around 87 in 2003 (Pimm et al. 2006, Johnson et al. 2010). Thus, by increasing genetic variability and introducing novel gene combinations, hybridization can provide small, struggling populations with the genetic flexibility needed to thrive and colonize new habitats (Seehausen et al. 2007).

In many cases, however, introduction of non-native organisms, especially through anthropogenic pathways, often leads to ecological harm and loss of biodiversity (Huxel 1998). Such ecological disturbance is well-illustrated by the emergence of a hybrid swarm of salamanders in Salina, California, the result of the introduction of the invasive barred tiger salamander (*Ambystoma tigrinum mavortium*). This invasive amphibian became established in the area in the 1950s after it was imported for use as fishing bait, and subsequently began interbreeding with the native, endangered California tiger salamander (*Ambystoma californiense*). Evidence suggests that the resultant hybrid salamanders became far more successful than either of their parent species; mixed-ancestry genotypes attained higher survival rates than genotypes containing mostly native or mostly introduced alleles (Fitzpatrick and Shaffer 2004). Further, it was discovered that the larvae of the native California tiger salamander were negatively impacted by the presence of hybrid larvae: metamorphic timing for the native larvae was increased, and fewer native larvae survived to metamorphosis. Those that did showed a measureable reduction in adult size. Other native community members were also affected: in ponds harboring well-established hybrid salamander populations, Pacific chorus frogs (*Pseudacris regilla*) and California newts (*Taricha torosa*) both showed decreased survival

(Ryan et al. 2009). Such hybrid swarms may form following the introduction of a non-native species, with the potential to decrease biodiversity by out-competing native taxa (Ward et al. 2012). This risk has risen as human-facilitated invasions of non-native species have become more common (Glutzbecker et al. 2016).

Hybridization is not always the result of sudden introduction, however, nor is it always anthropogenic in origin. As much as 10 to 30% of the world's plant and animal species are known to hybridize on a regular basis; thus, hybridization likely plays an integral role in the process of evolution and genetic diversification (Saetre 2013). Among turtle species, distantly related lineages have been known to hybridize (Parham et al 2013). For example, green sea turtle (*Chelonia mydas*) and hawksbill sea turtle (*Eretmochelys imbricata*) hybrids have been captured in both the Western Atlantic and the Eastern Pacific, although the two genera have likely been separated for over 50 million years (Seminoff et al. 2003). The ability of green sea turtles and hawksbill sea turtles to hybridize after tens of millions of years of divergence has been explained in part by the slow rate of morphological and genomic evolution inherent in the order Testudines (Avice et al. 1992, Seminoff et al. 2003, Schaffer et al. 2013). Because of this, many turtle species readily hybridize in the wild. This can cause widespread taxonomic confusion, especially among related, morphologically similar species. In the United States, this is well illustrated by the endemic genus *Pseudemys* (Seidel and Smith 1986, Seidel 1994, Spinks et al. 2009, Jackson et al. 2012).

Pseudemys is a genus of freshwater turtles (family Emydidae, subfamily Deirochelyinae) made up of several species and subspecies distributed throughout the southeastern region of the United States and south into northern Mexico (Conant and Collins, 2002). Although this genus is the second largest in Deirochelyinae, its phylogeny is poorly understood and remains a point of

contention for many taxonomists (Seidel and Smith 1986, Seidel 1994, Spinks et al. 2009, Jackson et al. 2012), with some arguing that the *Pseudemys* genus has been oversplit (Spinks et al. 2013).

For centuries, the genus *Pseudemys* has been subject to considerable taxonomic revision due to changes in nomenclature, as well as phylogenetic and taxonomic confusion (Seidel and Smith 1986, Mitchell 1994, Siedel and Ernst 1996, Jackson et al. 2012). For example, Seidel and Ernst list no fewer than 36 accounts of taxa, including historically proposed subspecies, in their summary of the taxonomy of the river cooter, *Pseudemys concinna*. Although debate on the validity of certain river cooter subspecies continues, two are widely accepted: the eastern river cooter (*Pseudemys concinna concinna*) and the Suwannee cooter (*Pseudemys concinna suwanniensis*; Ward and Jackson 2008).

Other *Pseudemys* species have similarly convoluted taxonomic histories (Michell 1994, Ernst and Lovich 2009). However, it is generally accepted that the genus *Pseudemys* can be broken down into two distinct subgeneric clades: the red bellied cooters and the river cooters (Seidel 1994, Jackson et al. 2012). Red bellied cooters are characterized by a conspicuous notch on the upper jaw, which is bordered by tooth-like cusps (Figure 1) and a pinkish, orange or red colored ventral shell, or plastron (Mitchell 1994, Ernst and Lovich 2009). Morphologically, the river cooters are highly variable, fueling controversy on taxonomic organization and assignment (Seidel and Smith 1986, Seidel 1994). However, the river cooter complex can generally be characterized by the absence of tooth-like cusps on the upper jaw, except in *P. gorguzi* and *P. texana* (Figure 2; Seidel 1994).

The Commonwealth of Virginia is home to three species in the genus *Pseudemys*: the northern red bellied cooter (*Pseudemys rubriventris*), the eastern river cooter (*Pseudemys*

concinna concinna) and the coastal plain cooter (*Pseudemys floridana*; Ernst and Lovich 2009). The coastal plain cooter, however, is thought to inhabit only the extreme southeastern corner of the Commonwealth (Siedel and Palmer 1991, Seidel 1994, Aresco 2006, Uwe and Havas 2007), and tends to prefer lentic waters, rather than the riverine environments explored in this study. (Jackson 1995). Under IUCN criteria, the eastern river cooter is listed as least concern (LC), while the northern red bellied cooter is listed as near-threatened (NT; IUCN 2013). Neither species is listed in the United States Fish and Wildlife Service Threatened and Endangered Species System (TESS) for the Commonwealth of Virginia. However, the northern red bellied cooter is listed as threatened on the United States Federal Endangered Species list (Pearson et al. 2015), and is considered endangered in the Commonwealth of Massachusetts, where a disjunct population occurs (Massachusetts Division of Fisheries & Wildlife, 2015, Browne 1996). The eastern river cooter is listed as endangered in the states of Indiana (Indiana Legislative Services Agency, 2016) and Illinois (Illinois Department of Natural Resources, 2015).

Many *Pseudemys* specimens from central and southeastern Virginia have been found with intermediate features, or with indicator features of both eastern river cooters and northern red bellied cooters (Crenshaw 1965, Seidel and Palmer 1991). Although it has been suggested that the northern red bellied cooter tends to maintain genetic integrity in regions shared with other *Pseudemys* species (Palmer and Braswell 1995), these atypical specimens could be indicative of recent hybridization events, or perhaps long-term introgression occurring in the species' sympatric territories. We predict that, given the propensity for even distantly related turtle lineages to hybridize (Parham et al 2013), as well as the fact that northern red bellied cooters and eastern river cooters inhabit overlapping territories in east-central Virginia,

phenotypic evidence for hybridization will be apparent in specimens found throughout the sympatric zone.

To investigate this supposition, we analyzed several purebred museum voucher (MV) eastern river cooters and northern red bellied cooters from the Smithsonian Museum Support Center in Suitland, Maryland. To reduce the effect of clinal variation from across the species' distribution, only specimens from Virginia waterways were selected for analysis, yielding a sample of 20 MV eastern river cooters and 25 MV northern red bellied cooters. We compared these museum voucher specimens to individuals caught at three riverine sites within east-central Virginia. The field caught specimens were initially identified based on the presence of generally accepted indicator traits. They were then compared to the MV groups using traditional phenotypic metrics, including the ratio of shell height to carapace length, and the ratio of plastron length to carapace length. The shape of the upper jaw as well as plastral scute proportions were analyzed using landmark-based morphometric software. Finally, the field-caught specimens were analyzed for intermediacy between the MV groups using several statistical analyses: one-way ANOVA tests were used to determine whether significant differences between the simple phenotypic metrics of the three groups exist, and Tukey post-hoc analyses identified which groups differ from each other. Morphometric variation, defined by geometric landmark data, was analyzed using principal component analysis (PCA). Discriminant function analyses determined whether the MV groups were morphologically distinct, while linear discriminant analyses were used to illustrate morphological separation between all three groups.

2. Methods and Analyses

2.1. Species Identification

The eastern river cooter and the northern red bellied cooter are known to inhabit sympatric territories throughout central and southeastern Virginia (Figure 3). Both species seek out fresh-tidal environments characterized by flowing, deep-bodied streams with muddy or rocky substrate, ample aquatic vegetation, and abundant basking sites (Buhlmann and Vaughn 1991, Ernst and Lovich 2009). The two species are morphologically similar. They display the same carapacial (dorsal shell) scute pattern, consisting of 24 marginal scutes (12 on each side of the nuchal scute), 8 pleural scutes (4 on each side of the vertebrae) and 5 vertebral scutes (Figure 4). They also exhibit a similar variety of carapacial colorations and striping patterns, and similar size and shape (Ernst and Lovich 2009, Mitchell 1994). However, red-bellied cooters and eastern river cooters can be distinguished by certain physical traits.

In addition to their characteristic notched upper jaw, northern red bellied cooters often display a prefrontal arrow-shaped marking formed by two thin stripes on the dorsum of the head that merge at the snout (Figure 5), and a broad, reddish vertical stripe on the second pleural scutes, which forks at the upper and/or lower end (Figure 6). Generally, each marginal scute also sports a single reddish vertical stripe (Ernst and Lovich 2009). The distinctive reddish plastron generally measures 88-98% of the carapace length (Mitchell 1994). Eastern river cooters are likely to sport whorling concentric circles on the carapace, including backwards C-shaped markings on the second pleural scutes (Figure 7; Bayless 1972). These markings, however, may

be obscured by melanism as the turtle ages (Webb 1961). In the field, carapace markings are often obscured by the accumulation of mossy algae on the shell surface. Dark circular markings with pale centers are often visible on the underside of the marginal scutes. These markings may resemble small, thick tires or donuts (Figure 8). The plastron is generally pale yellow to orange (Ernst and Lovich 2009), its length measuring 79-97% of the carapace length (Mitchell 1994). The upper jaw of eastern river cooter specimens may be notched in the center, but tooth-like cusps are not present (Ernst and Lovich 2009). The presence or absence of some of these features should help with accurate identification of each species in the field.

2.2 Study Sites

Three riverine locations in eastern Virginia were chosen for sampling (Figure 9). The first site, Morris Creek, is a tidal freshwater system situated within Charles City County, VA. It runs northwest to southeast, covering 8.1 km from its headwaters to the mouth, which flows into the Chickahominy River. Morris Creek itself is fed by numerous narrow, meandering channels. The study site encompasses approximately 69 ha, and is characterized by the presence of broad-leaf arrowhead (*Sagittaria latifolia*), water hyacinth (*Eichhornia crassipes*), and bladderwort (genus *Utricularia*).

The second site is the Walkerton area of the Mattaponi River in King and Queen County, VA. Walkerton is a fresh tidal system situated on the border between King and Queen County and King William County, VA. The Mattaponi River flows from northwest to southeast for approximately 166 km, and drains into the York River near West Point, VA. The study site on the Walkerton area spans 4.3 km and an area of approximately 107 ha. Dominant plant species include pickerelweed (*Pontederia cordata*), marsh hibiscus (*Hibiscus moscheutos*) and broadleaf

arrowhead (*Sagittaria latifolia*).

The third site, Totusky Creek, is a tidal freshwater tributary of the Rappahannock River in Warsaw County, VA. It runs northeast to southwest, flowing 27 km from its headwaters in southeast Richmond County to the mouth, which feeds into the Rappahannock River near Wellford, VA. The study site itself covers a distance of approximately 4.6 km, and an area of approximately 65 ha. It is characterized by the presence of silt and clay-rich mudflats. Dominant plant species include big cordgrass (*Spartina cynosuroides*).

2.3 Data Collection

Specimens were collected, measured, and released over the course of four field seasons; the first field season lasted from July to September 2012. The second lasted from May to September 2013. The third lasted from May until September 2014. The fourth and final season lasted from July until October 2015. During each day of sampling, hoop net traps were set at twenty randomly chosen locations on one of the three sites. Each site was sampled for four weeks during each season. Each captured *Pseudemys* specimen was measured across the following morphometrics: curved carapace length (CCL), straight-line carapace length (CL), carapace width (CW), plastron length (PL), plastron width (PW), length of the posterior lobe of the plastron (Post-L) and the distance between the cloaca and the posterior lobe of the plastron (Pre-Clo; Figure 10). Turtles were sexed based on the presence of elongated foreclaws, which are prominent in adult males but absent in females, as well as precloacal tail length, which is larger in males (Mosimann and Bider 1960, Rivera 2008). Each specimen was also weighed and the shell notched with unique markings for future identification before being photographed with a Canon SX40 HS 12.1MP Digital Camera, and finally released at the site of capture. The

morphometric data was then compiled into a database for future reference. A total of 188 unique specimens were collected and measured in the field.

The field data was subsequently organized and digitized. Landmark-based morphometric data was recorded using TpsDig, a popular program for digitizing landmarks and outlines for geometric morphometric analyses (Rohlf 2015). Museum voucher (MV) specimens of each species were measured and photographed at the Smithsonian Museum Support Center in Suitland, Maryland, yielding three sample groups: MV eastern river cooters (n=20), MV northern red bellied cooters (n=25) and field-collected specimens in the genus *Pseudemys* (n=188).

2.4 Measurement-based morphometric data

Proportions have been historically used in phylogenetic analyses in many animal groups (Baur and Leuenberger 2011). Because the ratios of both plastron length to carapace length and shell height to carapace length are commonly used metrics in the discussion of turtle phenotypes, these two proportions were included in the analysis. However, the carapace of female turtles generally shows greater convexity than that of males, so the ratio of carapace length to shell height was calculated only for male specimens. The proportions calculated for each museum-voucher specimen were initially analyzed using a t-test to determine whether there exists a significant difference between the two groups as represented by the MV specimens. Each morphometric ratio was then analyzed across all three groups using a one-way analysis of variance (ANOVA) with post-hoc Tukey HSD (Honestly Significant Difference) test to determine whether there exists a significant difference between the groups, and to determine which means are significantly different from each other.

2.5. Landmark-based geometric morphometrics: plastron shape data

After the specimens were photographed, geometric morphometric data describing plastron shape was gathered. The x, y coordinates of eleven Type 1 anatomical landmarks and one Type 2 anatomical landmark (Figure 11) were recorded using TpsDig, a popular program for digitizing landmarks and outlines for geometric morphometric analyses (Rohlf 2015). The Type 1 landmarks include the intersections of the lines delineating the gular, humeral, pectoral, abdominal, femoral and anal scutes. The Type 2 landmark (LM6) marks the local minima of the curve defining the anal scute. To avoid redundancy, only the right half of the plastron was used in the analysis. It is assumed that the plastrons are roughly symmetrical, and therefore, interpretation of the results would apply equally to either side (Rivera 2008, Myers et al. 2007). In cases where the right side of the specimen's plastron was damaged or obscured, the image was mirrored, and the left side digitized instead (Rivera 2008). The chosen landmarks were based on a previous study (Myers et al. 2007) of plastron shape in the slider turtle *Trachemys scripta elegans*, a related emydid turtle also in the subfamily Deirochelyinae (Spinks et al. 2009).

Using the MorphoJ integrated software package for geometric morphometrics, a Generalized Procrustes Analysis was performed (Klingenberg 2011). This process both superimposed the specimens to a common coordinate system and mathematically eliminated the effects of digitizing position, orientation and scale (Rohlf and Slice 1990, Myers et al. 2007), yielding calculated coordinate positions for an average specimen (Figure 12). After all landmarks were digitized and the average specimen calculated, a principal component analysis (PCA) was run on the Procrustes coordinate data to determine morphometric variation between the three

groups. A linear discriminant analysis was then run on the Procrustes coordinate data to determine the degree of morphological separation between the three groups.

2.6. Landmark-based geometric morphometrics: upper jaw shape data

The same procedures used to quantify plastron shape data were repeated for upper jaw shape data; the x, y coordinates of six anatomical landmarks (Figure 13) were recorded using TpsDig (Rohlf 2015). These landmarks included the palpebra inferior, the local minima of the curve of the upper jaw just below the palpebra inferior, two local maxima and one local minima of the curve delineating the jaw line, the and the midpoint of the septum. Again, because it is assumed that jaw outlines are a generally symmetrical feature, only the right side of the upper jaw was digitized to avoid redundancy. In cases where the right side of the specimen's upper jaw was damaged or obscured, the image was mirrored, and the left side digitized instead (Rivera 2008). Like with the plastron images, a Generalized Procrustes Analysis was also performed with the upper jaw landmark data, yielding calculated coordinate positions for an average specimen (Klingenberg 2011, Figure 14). After all landmarks were digitized and the average specimen calculated, a principal component analysis was run on the Procrustes coordinate data to determine morphometric variation between the three groups. A linear discriminant analysis was then run on the Procrustes coordinate data to determine the degree of morphological separation between them.

3. Results

3.1 Trait-based morphological analysis

The majority of field-collected specimens displayed physical traits consistent with northern red bellied cooters; all field collected specimens displayed the double-cusped upper jaw indicative of northern red bellied cooters. However, thirteen specimens exhibited indicator traits of both northern red bellied cooters and eastern river cooters. Seven of these specimens were captured at the Walkerton site, five were captured at the Totusky Creek site, and one was captured at the Morris Creek site (Table 1). Ten of these phenotypically intermediate specimens exhibited the concentric circles and/or backwards-C shaped carapace markings associated with eastern river cooters, while also displaying the double-cusped upper jaw indicative of northern red bellied cooters. Six of these specimens displayed the vivid red plastron coloration associated with northern red bellied cooters as well as the carapace patterning and “donut” shaped plastron markings indicative of eastern river cooters.

3.2. Measurement-based morphological analysis

As represented by the MV specimens, northern red bellied cooters and eastern river cooters showed distinct morphologies. A significant difference in plastron length as a percentage of carapace length was found ($p < 0.00001$), with the average plastron of a northern red bellied cooter comprising 92% of the carapace length, and the average plastron of an eastern river cooter

comprising 87% of the carapace length. The three groups were then analyzed together using a one-way ANOVA test to determine whether significant differences in the ratio of plastron length to carapace length exist between them. It was determined that a significant difference in means between two or more groups exists ($p < 0.0001$, Table 2). In field-collected specimens, plastron length averaged 94% of carapace length (Table 3). A Tukey post-hoc analysis determined that a significant difference exists between field-collected specimens and eastern river cooters as well as between eastern river cooters and northern red bellied cooters.

A significant difference in shell height as a proportion of carapace length ($p = 0.0016$) between the two MV groups also exists, with the MV northern red bellied cooters being more domed than the eastern river cooters. Using a one-way ANOVA test for shell height as a proportion of carapace length, the three groups were then analyzed together. It was determined that a significant difference in means between two or more groups exists ($p < 0.0001$, Table 4). In field-collected specimens, shell height averaged 34% of carapace length, while in the MV eastern river cooters and northern red bellied cooters, shell height averaged 27% and 31% of carapace length, respectively (Table 5). A Tukey post-hoc analysis determined that a significant difference exists between field-collected specimens and eastern river cooters only.

3.3. Landmark-based morphological analysis

After all landmarks were digitized and the average specimen calculated, morphometric variation was analyzed using principal component analysis (PCA). For plastron shape, 24 principal components were detected, with the first and second comprising 43% of the total variance (Table 6) Principal component 1 codes for shortening of the gular, humeral, and pectoral scutes, and elongation of the femoral and anal scutes (Figure 15). Principal component 2

codes for elongation and broadening of the gular, humeral, pectoral and anal scutes, and a broadened femoral scute (Figure 16).

A PCA was first executed on the plastral scute coordinate data of the MV groups to determine morphological variation inherent between them (Figure 17). A discriminant function analysis was then run using the MorphoJ integrated software package, which found a significant difference between the plastral landmark locations of each species ($p = 0.0002$). A confusion matrix was also generated to evaluate the precision of the discriminant function analysis. This model correctly classified eastern river cooters 100% of the time. Northern red bellied cooters were correctly classified 100% of the time. Although the cross-validation analysis was less accurate, eastern river cooters and northern red bellied cooters could still be correctly classified based on their plastral morphology 80% of the time and 72% of the time, respectively (Table 7). The separation achieved by the discriminant function analysis is illustrated in Figure 18.

A PCA was then run on the plastron shape coordinate data for all three groups to visualize the morphometric variation between them (Figure 19). A linear discriminant analysis run on the plastral scute data returned two linear discriminant dimensions, with the first dimension achieving 64% separation (Figure 20), and the second achieving 36% separation (Figure 21). A scatterplot of the two linear discriminant functions shows that the three groups are well separated, but some overlap exists (Figure 22). The field collected specimens appear to be morphologically intermediate on the second linear discriminant dimension only.

Unlike plastron scute proportions, differences in the shape of the upper jaw are a commonly used indicator trait to differentiate between species in the field. For upper jaw shape, 12 principal components were detected, with the first and second comprising 72% of the total

variance (Table 8). Principal component 1 codes for a narrower, more deepened jaw (Figure 23), while principal component 2 codes for a wider, shorter jaw with shallow cusps (Figure 24).

Again, a PCA was first run on the two MV groups to determine the degree of inherent morphological variation between them (Figure 25). A discriminant function analysis was then run, which found a significant difference between the upper jaw landmark locations of each species, as represented by the MV specimens ($p < 0.0001$). The model generated from this analysis correctly classified eastern river cooters 95% of the time. Northern red bellied cooters were correctly classified 92% of the time. Although the cross-validation analysis was less accurate, eastern river cooters and northern red bellied cooters could still be correctly classified based on their plastral morphology 85% of the time and 80% of the time, respectively (Table 9). The separation achieved by the discriminant function analysis is illustrated in Figure 26.

A PCA was then run on the jaw shape coordinate data for all three groups in order to visualize the morphometric variation between them (Figure 27). A linear discriminant analysis run on the jaw shape data returned two linear discriminant dimensions, with the first dimension achieving 78% separation (Figure 28), and the second achieving 22% separation (Figure 29). A scatterplot of the two linear discriminant functions shows some separation between the jaw shape of eastern river cooters and the two remaining groups, and considerable overlap between the jaw shape data of northern red bellied cooters and field-collected specimens (Figure 30).

4. Discussion

Analysis of the measurement-based morphological data associated with field collected specimens shows consistency with the measurements for northern red bellied cooters, rather than intermediacy. MV northern red bellied cooters could be distinguished from MV eastern river cooters by their longer plastrons and greater shell height in relation to carapace length, but field collected specimens exhibit longer plastrons and higher shells in proportion to carapace length than either MV group, although these differences are not statistically significant when compared to MV red bellied cooters. This is not unexpected, as the majority of field collected specimens also displayed indicator traits consistent with northern red bellied cooters.

Geometric morphometric analysis of the plastral scutes and jaw shapes of field collected specimens reveals considerable phenotypic variability: data points describing these shapes in the field specimens overlap with data points for both MV eastern river cooters and MV northern red bellied cooters, while also displaying morphological extremes beyond the dimensions characterized by either MV group. This illustrates the limitations of attempts to classify hybrid individuals of morphologically variable species through morphological analyses alone; in a 1987 study on hybridization in anuran frogs, Lamb and Avise found that 40% of the hybrid frogs studied would have been misclassified as "pure" parental species, had the classification been made based on morphology alone (Lamb and Avise 1987). In such cases, dominance of a single parental phenotype in a known hybrid zone may lead to instances of species erosion by hybridization being mistaken for species displacement without hybridization (Ward et al. 2012).

On an individual level, hybridization may be better supported through morphological analyses in species where suspected parental taxa display less variability, and can instead be characterized by well separated morphological extremes (Murrell 1994). As a population, however, increased levels of introgressive hybridization have been associated with increased phenotypic variability in the hybrid swarm (Seehausen 2006, Ward et al. 2012).

The most tangible evidence for hybridization events between eastern river cooters and northern red bellied cooters examined in this study is the existence of specimens exhibiting phenotypes associated with both supposedly parental species. Specimens showing morphological intermediacy between two sympatric species are commonly attributed to interspecific hybridization (Wolf and Mort 1986). Several captured *Pseudemys* specimens displayed carapace markings consistent with eastern river cooters, while at the same time exhibiting coloration and jaw shape consistent with northern red bellied cooters. In the case of sea turtles (family Cheloniidae), most initial studies involving hybridization were based solely on the description of individuals with intermediate morphological characters. The hybrid origin of these specimens was later confirmed using nuclear markers (Vilaça et al. 2012).

The expression of intermediate morphology has recently been shown to be a good indicator of hybrid origin, based on verification through molecular methods (Shriver et al. 2005, Vilaça et al. 2012, Parham et al. 2013), although such morphological intermediacy may be indicative of long-term introgression in turtle populations, rather than recent hybridization events (Fujii et al. 2014).

It has been suggested that hybridization may threaten regional biodiversity in areas where related species inhabit sympatric territories (J. E. et al. 2009, Lee 2012, Cordingley, Hegarty 2012, Söderquist et al. 2014). In the case of species within the genus *Pseudemys*, this should be

cause for concern; the Alabama red bellied cooter, *P. alabamensis*, is a red bellied cooter inhabiting a severely restricted territory in the drainages of the Mobile-Tensaw Delta in Mobile and Baldwin counties, Alabama, as well as the Pascagoula River and Back Bay of Biloxi watersheds in Harrison and Jackson counties, Mississippi (Leary et al. 2008). It is considered one of the most endangered turtle species in North America (Nelson et al. 2009, Spinks et al. 2013). However, the turtle's territory is also home to substantial populations of eastern river cooters (Leary et al. 2008).

Hybridization between the eastern river cooter and the Alabama red bellied cooter is already suspected in the areas around Mobile Bay and western Mobile County, Alabama (Guyer et al. 2015). Although discussion of threats to the Alabama red bellied cooter's survival have often focused on habitat destruction, egg predation by raccoons and fish crows, drowning by fishermen's nets, and collision with boat propellers and road vehicles (Nelson et al. 2009), loss of genetic diversity via introgression with eastern river cooters may also pose a risk to the species' survival as a unique taxon, at least in certain regions.

This risk will likely increase as the rapid effects of anthropogenic climate change become more apparent. In North America, turtles have historically coped with climate change by shifting their geographic ranges to areas with more compatible climates; on average, each species' geographic range shifts an average of 2,000 km² for each degree of warming or cooling (Rödger et al. 2013). As the current warming trend continues, the Alabama red bellied cooter will likely be pushed northward, deeper into regions currently populated by eastern river cooters and other *Pseudemys* species. This may further endanger the genetic integrity of the Alabama red bellied cooter.

In the case of the genus *Pseudemys*, phenotypic evidence may be pointing to the existence of limited hybridization zones, challenging the perception of genetic isolation between the red bellied and river cooter complexes. A better understanding of the phylogeny of this perplexing genus is needed to more accurately predict the potential role that natural hybridization may play in the future of these ubiquitous freshwater turtles. This understanding will be best achieved through additional research utilizing molecular methods and genetic analysis.

References

- Abbott, R, D. Albach, S. Ansell, J. W. Arntzen, S. J. E. Baird, N. Bierne, J. Boughman, A. Brelsford, C. A. Buerkle, R. Buggs, R. K. Butlin, U. Dieckmann, F. Eroukhmanoff, A. Grill, S. H. Cahan, J. S. Hermansen, G. Hewitt, A. G. Hudson, C. Jiggins, J. Jones, B. Keller, T. Marczewski, J. Mallet, P. Martinez-Rodriguez, M. Möst, S. Mullen, R. Nichols, A. W. Nolte, C. Parisod, K. Pfennig, A. M. Rice, M. G. Ritchie, B. Seifert, C. M. Smadja, R. Stelkens, J. M. Szymura, R. Väinölä, J. B. W. Wolf, and D. Zinner. "Speciation and Hybridization." *Journal of Evolutionary Biology* 26.2 (2013): 229–246.
- Aresco, Matthew J., and James L. Dobie. "Variation in Shell Arching and Sexual Size Dimorphism of River Cooters, *Pseudemys Concinna*, from Two River Systems in Alabama." *Journal of Herpetology* 34.2 (2000): 313-17.
- Awise, J. C., B W Bowen, T Lamb, A B Meylan, and E Bermingham. "Mitochondrial DNA evolution at a turtle's pace: evidence for low genetic variability and reduced microevolutionary rate in the Testudines". *Molecular Biology and Evolution* 9.3 (1992): 457-473.
- Barton, Nicholas H. "Speciation." *Trends in Ecology & Evolution* 16.7 (2001): 325.
- Baur, H., and C. Leuenberger. "Analysis of Ratios in Multivariate Morphometry." *Systematic Biology* 60.6 (2011): 813-25.
- Bayless, Laurence E. "A New Turtle Record, *Chrysemys Floridana*, for West Virginia." *Journal of Herpetology* 6.1 (1972): 39.
- Browne, Robert A., N. Alison Haskell, Curtice R. Griffin, and Jeffrey W. Ridgeway. "Genetic Variation among Populations of the Redbelly Turtle (*Pseudemys Rubriventris*)." *Copeia* 1996.1 (1996): 192.
- Buhlmann, Kurt A., and Michael R. Vaughan. "Ecology of the Turtle *Pseudemys Concinna* in the New River, West Virginia." *Journal of Herpetology* 25.1 (1991): 72.

- Collyer, Michael L., Craig A. Stockwell, Dean C. Adams, and M. Hildegard Reiser. "Phenotypic Plasticity and Contemporary Evolution in Introduced Populations: Evidence from Translocated Populations of White Sands Pupfish (*Cyprinodon Tularosa*)." *Ecological Research* 22.6 (2007): 902-10.
- Collyer, Michael L., Jeffrey S. Heilveil, and Craig A. Stockwell. "Contemporary Evolutionary Divergence for a Protected Species following Assisted Colonization." *Public Library of Science* 6.8 (2011).
- Conant, Roger, and Joseph T. Collins. *Reptiles and Amphibians of Eastern and Central North America*. Norwalk, CT: Easton, 2002.
- Coyne, Jerry A., and H. Allen Orr. *Speciation*. Sunderland, MA: Sinauer Associates, 2004.
- Crenshaw, John W. "Serum Protein Variation in an Interspecies Hybrid Swarm of Turtles of the Genus *Pseudemys*." *Evolution* 19.1 (1965): 1.
- Ernst, Carl H., and Jeffrey E. Lovich. *Turtles of the United States and Canada*. Baltimore: Johns Hopkins University, 2009.
- Fitzpatrick, Benjamin M., and H. Bradley Shaffer. "Environment-Dependent Admixture Dynamics In: A Tiger Salamander Hybrid Zone." *Evolution* 58.6 (2004): 1282.
- Fujii, Ryo, Hidetoshi Ota, and Mamoru Toda. "Genetic and Morphological Assessments of Hybridization Between Two Non-Native Geoemydid Turtles, *Mauremys reevesii* and *Mauremys mutica*, in Northcentral Japan." *Chelonian Conservation and Biology* 13.2 (2014): 191-201.
- Glutzbecker, Gregory J., David M. Walters, and Michael J. Blum. "Rapid Movement and Instability of an Invasive Hybrid Swarm." *Evolutionary Applications* 9.6 (2016): 741-55.
- Guo, Qinfeng. "Plant Hybridization: The Role of Human Disturbance and Biological Invasion." *Diversity and Distributions* 20.11 (2014): 1345-354.
- Hegarty, M. J. "Invasion of the Hybrids." *Molecular Ecology* 21.19 (2012): 4669-671.
- Hostetler, Jeffrey A., David P. Onorato, Benjamin M. Bolker, Warren E. Johnson, Stephen J. O'Brien, Deborah Jansen, and Madan K. Oli. "Does Genetic Introgression Improve Female Reproductive Performance? A Test on the Endangered Florida Panther." *Oecologia* 168.1 (2011): 289-300.
- Huxel, Gary R. "Rapid Displacement of Native Species by Invasive Species: Effects of Hybridization." *Biological Conservation* 89.2 (1999): 143-52.

- Illinois Department of Natural Resources. Illinois Endangered Species Protection Board. *Checklist of Illinois Endangered and Threatened Animals and Plants*, 2015.
- Indiana Legislative Services Agency. “312 IAC 9-5-4: Endangered species of reptiles and amphibians”, Indiana Administrative Code, 2016.
- Jackson, Dale R. “Systematics of the *Pseudemys Concinna-Floridana* Complex.” *Chelonian Conservation and Biology* 1.4 (1995): 329-333.
- Jackson, Thomas G., David H. Nelson, and Ashley B. Morris. “Phylogenetic Relationships in the North American Genus *Pseudemys* (Emydidae) Inferred from Two Mitochondrial Genes.” *Southeastern Naturalist* 11.2 (2012): 297-310.
- Johnson, Warren E., David P. Onorato, Melody E. Roelke, E. Darrell Land, Mark Cunningham, Robert Belden, Roy McBride, Deborah Jansen, Mark Lotz, David Shindle, JoGayle Howard, David E. Wildt, Linda M. Penfold, Jeffrey A. Hostetler, Madan K. Oli, and Stephen J. O’Brien. “Return of the Florida Panther.” *Science* 329.5999 (2010): 1571.
- Klingenberg, C. P. 2011. MorphoJ: an integrated software package for geometric morphometrics. *Molecular Ecology Resources* 11: 353-357.
- Kubatko, L. S. “Identifying Hybridization Events in the Presence of Coalescence via Model Selection.” *Systematic Biology* 58.5 (2009): 478-88.
- Lamb, Trip, and John C. Avise. “Morphological Variability in Genetically Defined Categories of Anuran Hybrids.” *Evolution* 41.1 (1987): 157-65.
- Leary, Christopher, James Dobie, Thomas Mann, and Peter Floyd. “*Pseudemys Alabamensis* Baur 1893 - Alabama red Bellied Cooter, Alabama red Bellied Turtle.” *Conservation Biology of Freshwater Turtles and Tortoises: Chelonian Research Monographs* 5 (2008): 019.1-19.9.
- Lee, David S. “The Future of Map Turtles: Will the Mutts Take Over?” *Bulletin of the Chicago Herpetological Society* 47.5 (2012): 57-62.
- Linder, C. R., and L. H. Rieseberg. “Reconstructing Patterns of Reticulate Evolution in Plants.” *American Journal of Botany* 91.10 (2004): 1700-708.
- Martin, Bradley T., Neil P. Bernstein, Roger D. Birkhead, Jim F. Koukl, Steven M. Mussmann, and John S. Placyk Jr. “On the Reclassification of the *Terrapene* (Testudines: Emydidae): A Response to Fritz & Havaš.” *Zootaxa* 3835.2 (2014): 292-94.

- “Massachusetts List of Endangered, Threatened and Special Concern Species.” Energy and Environmental Affairs. Commonwealth of Massachusetts Division of Fisheries & Wildlife, 2015.
- Mayr, Ernst. *Systematics and the Origin of Species, from the Viewpoint of a Zoologist*. New York: Columbia University, 1942.
- Mitchell, Joseph C. *The Reptiles of Virginia*. Washington, DC: Smithsonian Institution, 1994.
- Mosimann, James E. and J. Roger Bider. “Variation, sexual dimorphism, and maturity in a Quebec population of the common snapping turtle, *Chelydra serpentina*.” *Canadian Journal of Zoology* 38.1 (1960): 19-38.
- Murrell, Zack E. “Dwarf Dogwoods: Intermediacy and the Morphological Landscape.” *Systematic Botany* 19.4 (1994): 539-56.
- Myers, E. M., J. K. Tucker, and C. H. Chandler. “Experimental Analysis of Body Size and Shape During Critical Life-history Events of Hatchling Slider Turtles, *Trachemys Scripta Elegans*.” *Functional Ecology* 21.6 (2007): 1106-114.
- Nelson, David H., Gabriel J. Langford, Joel A. Borden, and William M. Turner. “Reproductive and Hatchling Ecology of the Alabama Red-Bellied Cooter (*Pseudemys Alabamensis*): Implications for Conservation and Management.” *Chelonian Conservation and Biology*. 8.1 (2009): 66-73.
- Palmer, William M., and Alvin L. Braswell. *Reptiles of North Carolina*. Chapel Hill: University of North Carolina, 1995. 65.
- Parham, James F., Theodore J. Papenfuss, Peter Paul Van Dijk, Byron S. Wilson, Cristian Marte, Lourdes Rodriguez Schettino, and W. Brian Simison. “Genetic Introgression and Hybridization in Antillean Freshwater Turtles (*Trachemys*) Revealed by Coalescent Analyses of Mitochondrial and Cloned Nuclear Markers.” *Molecular Phylogenetics and Evolution* 67.1 (2013): 176-87.
- Pearson, Steven H., Harold W. Avery, and James R. Spotila. “Juvenile Invasive red eared Slider Turtles Negatively Impact the Growth of Native Turtles: Implications for Global Freshwater Turtle Populations.” *Biological Conservation* 186 (2015): 115-21.
- Rivera, G. "Ecomorphological Variation in Shell Shape of the Freshwater Turtle *Pseudemys Concinna* Inhabiting Different Aquatic Flow Regimes." *Integrative and Comparative Biology* 48.6 (2008): 769-87.
- Pimm, S. L., L. Dollar, and O. L. Bass. “The Genetic Rescue of the Florida Panther.” *Animal Conservation* 9.2 (2006): 115-22.

- Rödler, Dennis, A. Michelle Lawing, Morris Flecks, Faraham Ahmadzadeh, Johannes Dambach, Jan O. Engler, Jan Christian Habel, Timo Hartmann, David Hörnes, Flora Ihlow, Kathrin Schidelko, Darius Stiels, and P. David Polly. "Evaluating the Significance of Paleophylogeographic Species Distribution Models in Reconstructing Quaternary Range-Shifts of Nearctic Chelonians." *PLoS ONE* 8.10 (2013)
- Rohlf, F.J. TPSDig, Version 2.22. Department of Ecology and Evolution, State University of New York, Stony Brook, New York. (2015)
- Rohlf, F. James, and Dennis Slice. "Extensions of the Procrustes Method for the Optimal Superimposition of Landmarks." *Systematic Zoology* 39.1 (1990): 40.
- Ryan, M. E., J. R. Johnson, and B. M. Fitzpatrick. "Invasive Hybrid Tiger Salamander Genotypes Impact Native Amphibians." *Proceedings of the National Academy of Sciences* 106.27 (2009): 11166-1171.
- Saetre, G.P. "Hybridization Is Important in Evolution, but Is Speciation?" *Journal of Evolutionary Biology* 26.2 (2013): 256-58.
- Seehausen, Ole. "Conservation: Losing Biodiversity by Reverse Speciation." *Current Biology* 16.9 (2006): 334-337.
- Seehausen, Ole, Gaku Takimoto, Denis Roy, and Jukka Jokela. "Speciation Reversal and Biodiversity Dynamics with Hybridization in Changing Environments." *Molecular Ecology* 17.1 (2008): 30-44.
- Seidel, M.E. "Morphometric analysis and taxonomy of the cooter and red bellied turtles in the North American genus *Pseudemys* (Emydidae)". *Chelonian Conservation and Biology* 1 (1994):117–130.
- Seidel, M.E., and C.H. Ernst. *Pseudemys*. Catalogue of American amphibians and reptiles 625 (1996):1–7.
- Seidel, M.E., and H. M. Smith. 1986. "Chrysemys, Pseudemys, Trachemys (Testudines: Emydidae): Did Agassiz Have It Right?" *Herpetologica* 42.2 (1986):242-248.
- Seidel, M. E., and W. M. Palmer. "Morphological variation in turtles of the genus *Pseudemys* (Testudines: Emydidae) from central Atlantic drainages." *Brimleyana* 17 (1991): 105-135.

- Seminoff, Jeffrey, Stephen Karl, Tonia Schwartz, and Antonio Resendiz. "Hybridization of the Green Turtle (*Chelonia mydas*) and Hawksbill Turtle (*Eretmochelys imbricata*) in the Pacific Ocean: Indication of an Absence of Gender Bias in the Directionality of Crosses." *Bulletin of Marine Science* 73.3 (2003): 643-652.
- Shaffer, H. Bradley, Patrick Minx, Daniel E. Warren, Andrew M. Shedlock, Robert C. Thomson, Nicole Valenzuela, John Abramyan, Chris T. Amemiya, Daleen Badenhorst, Kyle K. Biggar, Glen M. Borchert, Christopher W. Botka, Rachel M. Bowden, Edward L. Braun, Anne M. Bronikowski, Benoit G. Bruneau, Leslie T. Buck, Blanche Capel, Todd A. Castoe, Mike Czerwinski, Kim D. Delehaunty, Scott V. Edwards, Catrina C. Fronick, Matthew K. Fujita, Lucinda Fulton, Tina A. Graves, Richard E. Green, Wilfried Haerty, Ramkumar Hariharan, Omar Hernandez, Ladeana W. Hillier, Alisha K. Holloway, Daniel Janes, Fredric J. Janzen, Cyriac Kandoth, Lesheng Kong, Ap De Koning, Yang Li, Robert Literman, Suzanne E. Mcgaugh, Lindsey Mork, Michelle O'laughlin, Ryan T. Paitz, David D. Pollock, Chris P. Ponting, Srihari Radhakrishnan, Brian J. Raney, Joy M. Richman, John St John, Tonia Schwartz, Arun Sethuraman, Phillip Q. Spinks, Kenneth B. Storey, Nay Thane, Tomas Vinar, Laura M. Zimmerman, Wesley C. Warren, Elaine R. Mardis, and Richard K. Wilson. "The Western Painted Turtle Genome, a Model for the Evolution of Extreme Physiological Adaptations in a Slowly Evolving Lineage." *Genome Biology* 14.3 (2013).
- Shriver, W. Gregory, James P. Gibbs, Peter D. Vickery, H. Lisle Gibbs, Thomas P. Hodgman, Peter T. Jones, and Christopher N. Jacques. "Concordance Between Morphological And Molecular Markers In Assessing Hybridization Between Sharp-Tailed Sparrows In New England." *The Auk* 122.1 (2005): 94-107.
- Söderquist, Pär, Joanna Norrström, Johan Elmberg, Matthieu Guillemain, and Gunnar Gunnarsson. "Wild Mallards Have More 'Goose-Like' Bills Than Their Ancestors: A Case of Anthropogenic Influence?" *PLoS ONE* 9.12 (2014): 1-14.
- Spinks, Phillip Q., Robert C. Thomson, Geoff A. Lovely, and Bradley H. Shaffer. "Assessing What Is Needed to Resolve a Molecular Phylogeny: Simulations and Empirical Data from Emydid Turtles." *BMC Evolutionary Biology* 9.1 (2009): 56.
- Spinks, Phillip Q., Robert C. Thomson, Gregory B. Pauly, Catherine E. Newman, Genevieve Mount, and H. Bradley Shaffer. "Misleading Phylogenetic Inferences Based on Single-exemplar Sampling in the Turtle Genus *Pseudemys*." *Molecular Phylogenetics and Evolution* 68.2 (2013): 269-81.
- Stephens, Patrick R., and John J. Wiens. "Convergence, Divergence, and Homogenization in the Ecological Structure of Emydid Turtle Communities: The Effects of Phylogeny and Dispersal." *The American Naturalist* 164.2 (2004): 244-54.
- Uwe, Fritz, and Peter Havas. "Genus *Pseudemys*." *Checklist of Chelonians of the World*. Dresden: Museum Für Tierkunde, 2007. 194-95.

- van Dijk, P.P. 2016. *Pseudemys concinna*. The IUCN Red List of Threatened Species 2016: e.T163444A97425355.
- van Dijk, P.P. 2016. *Pseudemys rubriventris*. The IUCN Red List of Threatened Species 2016: e.T163444A97425355.
- Vega, Yesenia, Isabel Marques, Sílvia Castro, and João Loureiro. “Outcomes of Extensive Hybridization and Introgression in Epidendrum (Orchidaceae): Can We Rely on Species Boundaries?” *PLoS ONE* 8.11 (2013).
- Vilaça, Sibelle T., Sarah M. Vargas, Paula Lara-Ruiz, Érica Molfetti, Estéfane C. Reis, Gisele Lôbo-Hajdu, Luciano S. Soares, and Fabrício R. Santos. “Nuclear Markers Reveal a Complex Introgression Pattern among Marine Turtle Species on the Brazilian Coast.” *Molecular Ecology* 21.17 (2012): 4300-312.
- Ward, Jessica L., Mike J. Blum, David M. Walters, Brady A. Porter, Noel Burkhead, and Byron Freeman. “Discordant Introgression in a Rapidly Expanding Hybrid Swarm.” *Evolutionary Applications* 5.4 (2012): 380-92.
- Wolf, Hans Georg, and Mona A. Mort. “Inter-specific Hybridization Underlies Phenotypic Variability in Daphnia Populations.” *Oecologia* 68.4 (1986): 507-11.
- Xu, Shizhong. “Phylogenetic Analysis Under Reticulate Evolution.” *Molecular Biology and Evolution* 17.6 (2000): 897-907
- Zinner, Dietmar, Michael L. Arnold, and Christian Roos. “The Strange Blood: Natural Hybridization in Primates.” *Evol. Anthropol. Evolutionary Anthropology: Issues, News, and Reviews* 20.3 (2011): 96-103.

Tables

Table 1. Indicator traits found in thirteen field-collected specimens. Where the trait is consistent with eastern river cooters, the trait is assigned “ERC”. Where the trait is consistent with northern red bellied cooters, the trait is assigned “RBC”. Where the trait is indiscernible using field photography, the trait is listed as N/A (not applicable).

ID	Jaw Shape	Carapace Pattern	Plastron Coloration	Arrow Marking (N=ERC, Y=RBC)	Donuts (Y=ERC, N=RBC)
28	RBC	ERC	RBC	RBC	ERC
47	RBC	ERC	RBC	RBC	ERC
48	RBC	ERC	ERC	RBC	ERC
78	RBC	ERC	ERC	N/A	RBC
125	RBC	ERC	ERC	N/A	ERC
134	RBC	N/A	ERC	RBC	ERC
152	RBC	ERC	RBC	RBC	ERC
157	RBC	ERC	RBC	RBC	ERC
173	RBC	ERC	RBC	N/A	ERC
174	RBC	RBC	ERC	RBC	ERC
189	RBC	RBC	ERC	N/A	RBC
196	RBC	ERC	RBC	RBC	ERC
200	RBC	ERC	ERC	ERC	ERC

Table 2. Summary of ANOVA for plastron length to carapace length ratios for three sample groups.

Source	SS	df	MS	F	P
Treatment [between groups]	0.099105	2	0.049552	21.31	<.0001
Error	0.534715	230	0.002325		
Ss/Bl					
Total	0.63382	232			

Table 3. Summary of plastron length to carapace length ratio data for three sample groups.

	Field specimens	Eastern river cooters	Northern red bellied cooters	Total
N	188	20	25	233
$\sum X$	177.372396	17.455219	22.922504	217.750119
Mean	0.94347	0.872761	0.9169	0.93455
$\sum X^2$	167.854108	15.2431	21.034957	204.132165
Variance	0.002719	0.000467	0.000721	0.002732
Std.Dev.	0.052148	0.021602	0.026856	0.052268
Std.Err.	0.003803	0.00483	0.005371	0.003424

Table 4. Summary of one-way ANOVA for shell height ratios for three sample groups; data taken for male specimens only.

Source	SS	df	MS	F	P
Treatment [between groups]	0.084439	2	0.04222	19.27	<.0001
Error	0.258483	118	0.002191		
Ss/Bl					
Total	0.342922	120			

Table 5. Summary of shell height ratio data for three sample groups; data taken for male specimens only.

	Field specimens	Eastern river cooters	Northern red bellied cooters	Total
N	90	19	12	121
ΣX	30.643325	5.121063	3.667599	39.431987
Mean	0.340481	0.26953	0.305633	0.325884
ΣX^2	10.669101	1.391283	1.1328	13.193183
Variance	0.002647	0.000611	0.001078	0.002858
Std.Dev.	0.051453	0.024725	0.032835	0.053457
Std.Err.	0.005424	0.005672	0.009479	0.00486

Table 6. Estimates of eigenvalues and percentage accumulated variation associated with principal components of plastral scute shape landmark data.

	Eigenvalues	%Variance	Cumulative%
1	0.00051557	28.321	28.321
2	0.00027424	15.064	43.386
3	0.00022385	12.296	55.682
4	0.00018765	10.308	65.99
5	0.00012334	6.775	72.765
6	0.00008461	4.648	77.413
7	0.00007994	4.391	81.804
8	0.00007203	3.957	85.761
9	0.00005323	2.924	88.685
10	0.00004512	2.479	91.163
11	0.00003382	1.858	93.021
12	0.00002509	1.378	94.399
13	0.00002166	1.19	95.589
14	0.00001963	1.078	96.668
15	0.00001654	0.908	97.576
16	0.00001405	0.772	98.348
17	0.00001161	0.638	98.985
18	0.00000779	0.428	99.413
19	0.00000636	0.349	99.763
20	0.00000432	0.237	100
Total variance: 0.00182045			

Table 7. Confusion matrix analyzing the precision of MorphoJ's discriminant function analysis of plastral shape data for MV eastern river cooters and MV northern red bellied cooters, with cross-validation scores.

Discriminant function analysis	Allocated to		
True	Eastern river cooter	Northern red bellied cooter	Total
Eastern river cooter	20	0	20
Northern red bellied cooter	0	25	25
Cross validation			
True	Eastern river cooter	Northern red bellied cooter	Total
Eastern river cooter	16	4	20
Northern red bellied cooter	7	18	25

Table 8. Estimates of eigenvalues and percentage accumulated variation associated with principal components of jaw shape landmark data.

	Eigenvalue	% Variance	Cumulative %
1	0.00874787	47.558	47.558
2	0.00441048	23.978	71.536
3	0.00206399	11.221	82.757
4	0.00128053	6.962	89.719
5	0.00078544	4.27	93.989
6	0.00056528	3.073	97.062
7	0.00030617	1.665	98.726
8	0.00023428	1.274	100
Total variance: 0.01839404			

Table 9. Confusion matrix analyzing the precision of MorphoJ's discriminant function analysis of jaw shape data for MV eastern river cooters and MV northern red bellied cooters, with cross-validation scores.

Discriminant function analysis	Allocated to		
True	Eastern river cooter	Northern red bellied cooter	Total
Eastern river cooter	19	1	20
Northern red bellied cooter	2	23	25
Cross validation			
True	Eastern river cooter	Northern red bellied cooter	Total
Eastern river cooter	17	3	20
Northern red bellied cooter	5	20	25

Figures

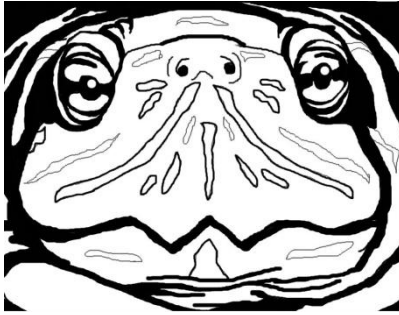

Figure 1. Double-cusped upper-jaw characteristic of the northern red bellied cooter and other red bellied cooters.



Figure 2. Absence of cusps on the upper jaw, characteristic of the eastern river cooter.

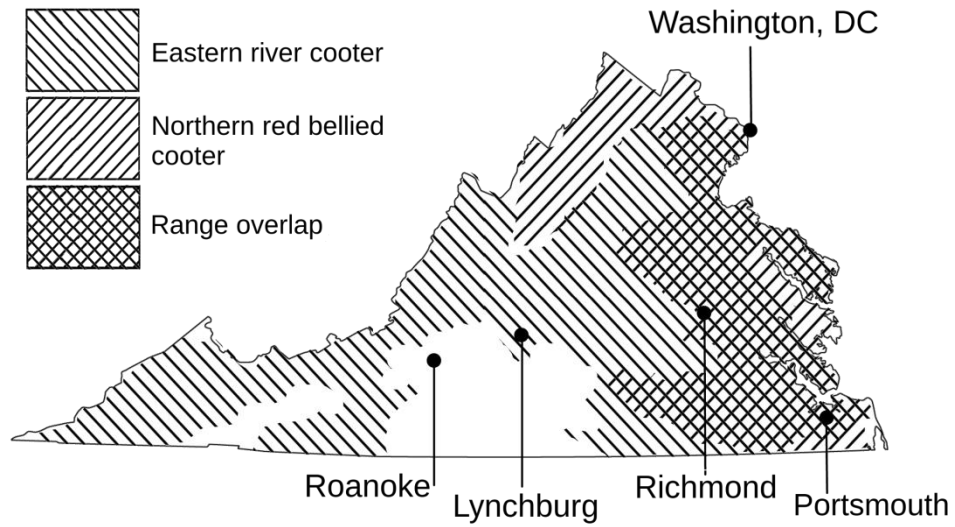

Figure 3. Map of known ranges of the eastern river cooter and northern red bellied cooter in Virginia. Redrawn from data collected from the IUCN Red List of Threatened Species. (van Dijk, 2016).

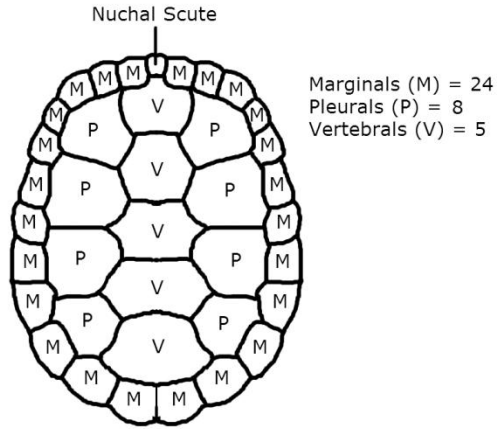

Figure 4. Typical carapacial scute pattern of both eastern river and northern red bellied cooters, where M = marginal scute, P = pleural scute, and V = vertebral scute.



Figure 5. Pre-frontal arrow-shaped marking characteristic of the northern red bellied cooter.

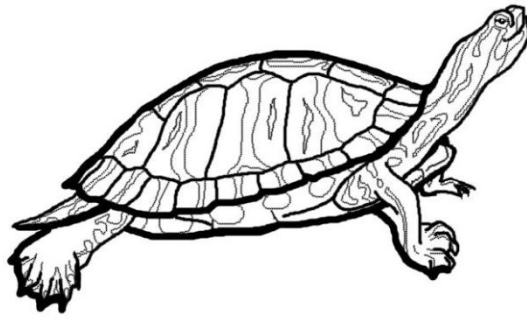

Figure 6. Forked vertical stripes on the carapace and marginal scutes, characteristic of the northern red bellied cooter.

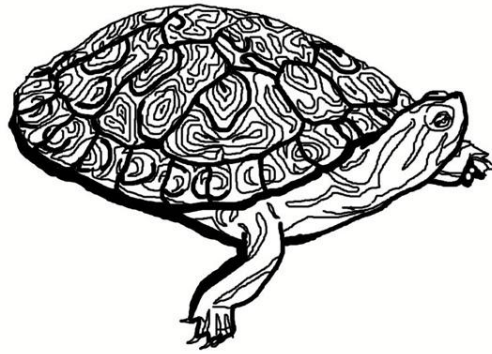

Figure 7. Whorling concentric circles on the carapace and backwards-facing C-shaped marking on the second pleural scute, characteristic of the eastern river cooter. Image drawn from photography provided by Pierson Hill.

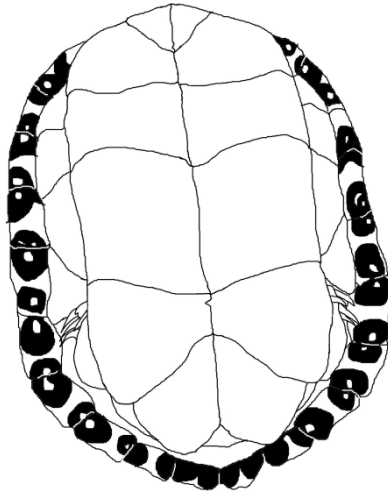

Figure 8. Donut-shaped markings on the underside of the marginal scutes, characteristic of the eastern river cooter.

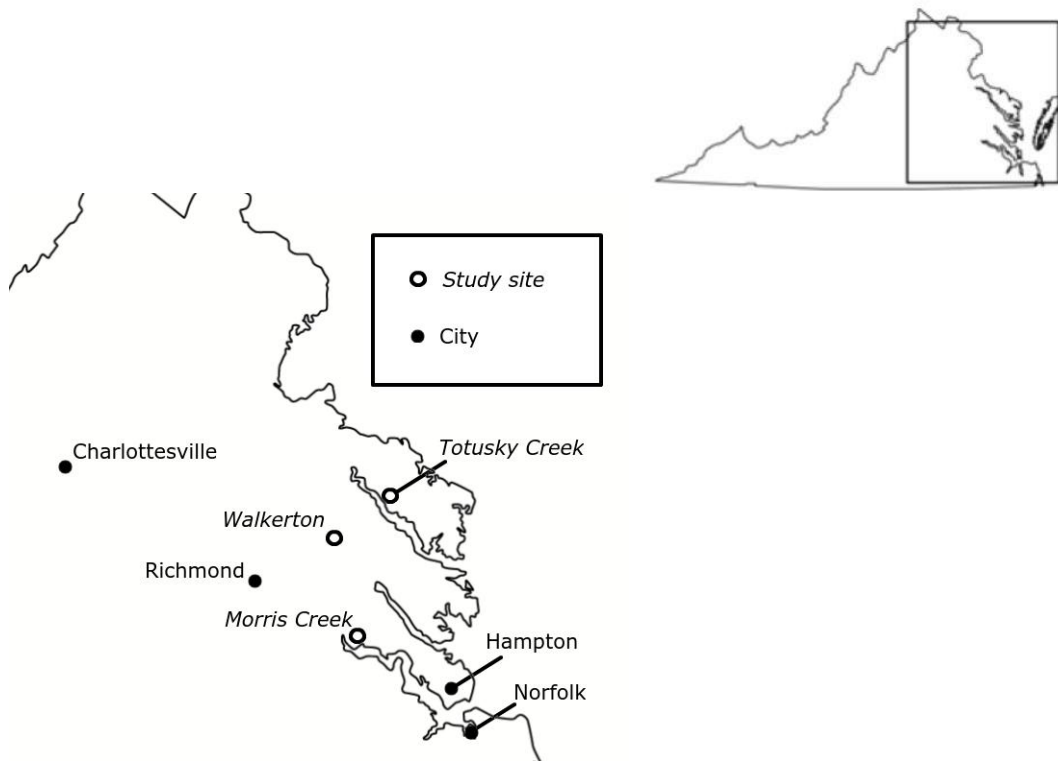

Figure 9. Map of eastern Virginia showing all three riverine study sites chosen for sampling of *Pseudemys* specimens. Study sites are denoted with hollow circles and labeled in italics, while major cities are denoted with solid circles.

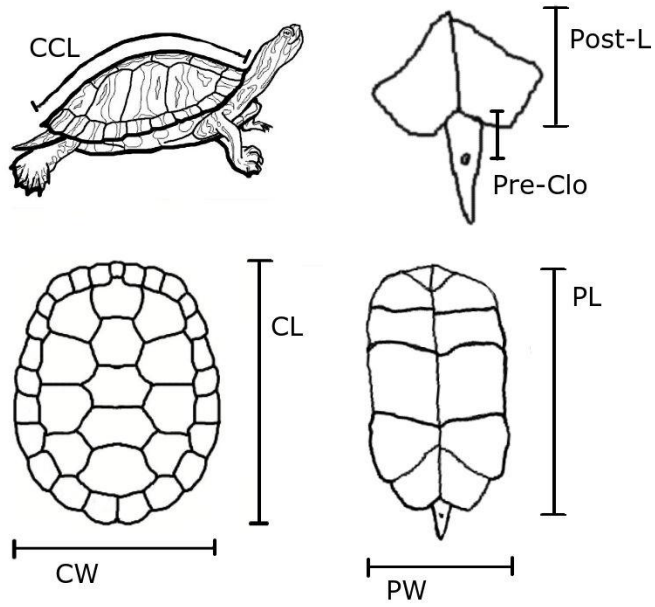

Figure 10. Diagram of relevant turtle measurements. CCL stands for curved carapace length, CL stands for straight-line carapace length, CW stands for carapace width, PL stands for plastron length, PW stands for plastron width, Post-L stands for the length of the posterior lobe of the plastron, and Pre-Clo stands for the distance between the cloaca and the posterior lobe of the plastron.

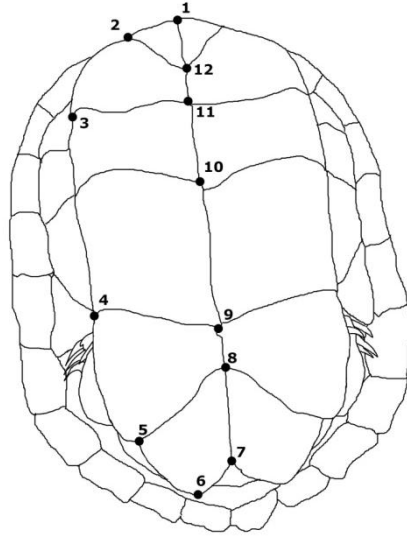

Figure 11. Ventral view of a *Pseudemys* specimen showing anatomical landmarks used in morphological analysis of the plastron.

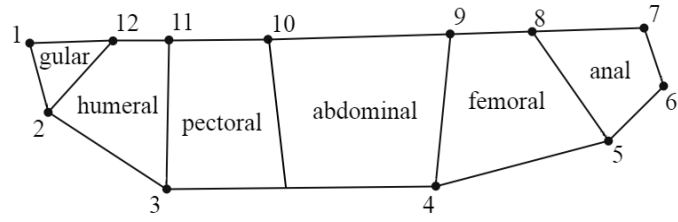

Figure 12. Generalized Procrustes superimposition showing average plastron shape of all *Pseudemys* specimens sampled, with scute types labeled.

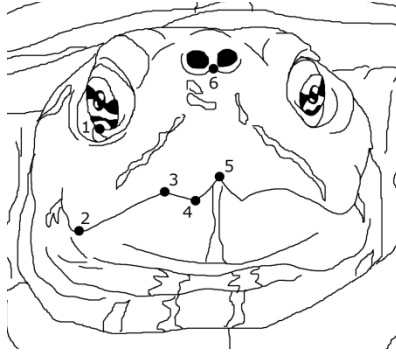

Figure 13. Head-on view of a northern red bellied cooter showing anatomical landmarks used in morphological analysis of the upper jaw.

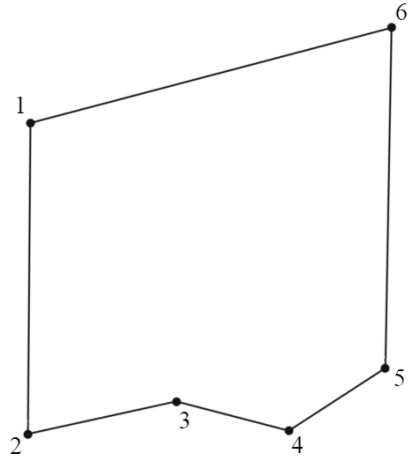

Figure 14. Generalized Procrustes superimposition showing average shape of the upper jaw of all *Pseudemys* specimens sampled.

PC1

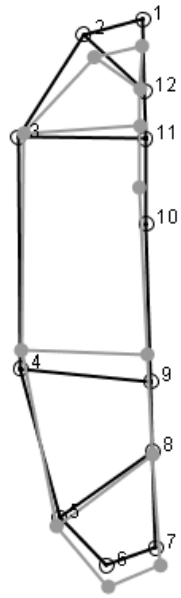
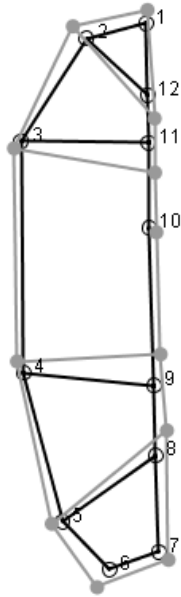

Figure 15. Wireframe graph showing the average plastron shape (as defined by generalized Procrustes superimposition) in black, and the plastron shape defined by principal component 1 in grey.



PC2

Figure 16. Wireframe graph showing the average plastron shape (as defined by generalized Procrustes superimposition) in black, and the plastron shape defined by principal component 2 in grey.

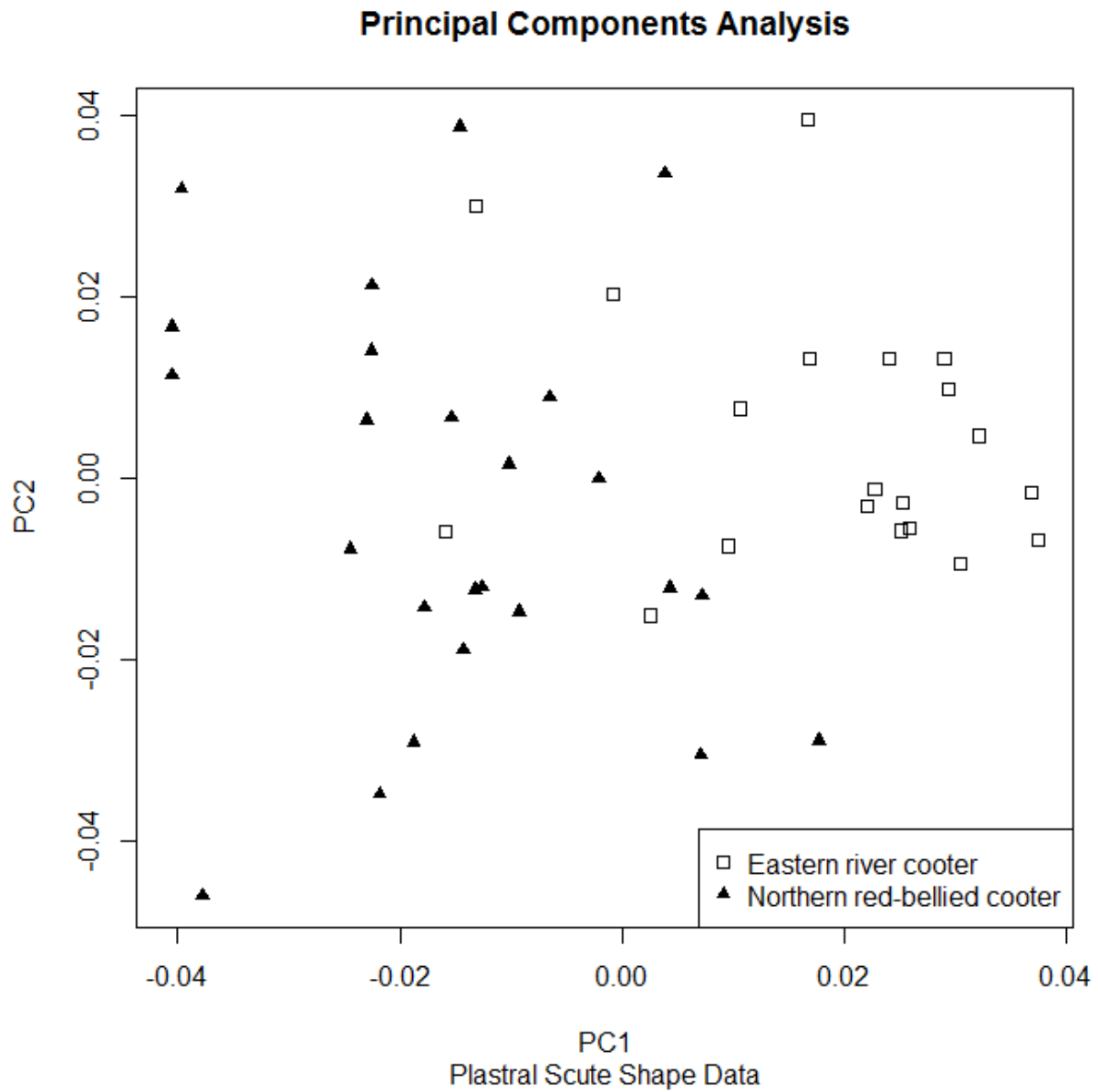

Figure 17. Plot of plastral scute shape data of MV specimens based on principal components one and two, comprising 43% of total variance. MV eastern river cooters are represented by hollow squares, and MV northern red bellied cooters are represented by solid triangles.

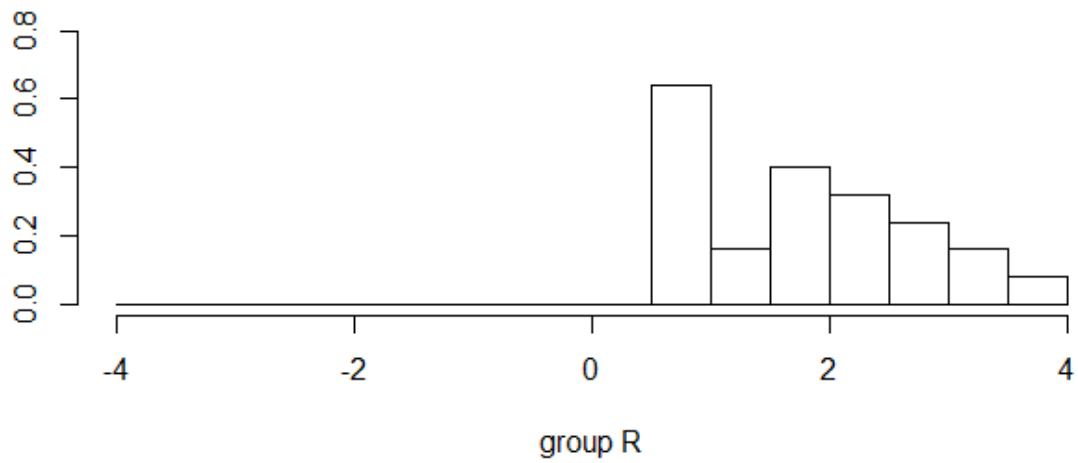
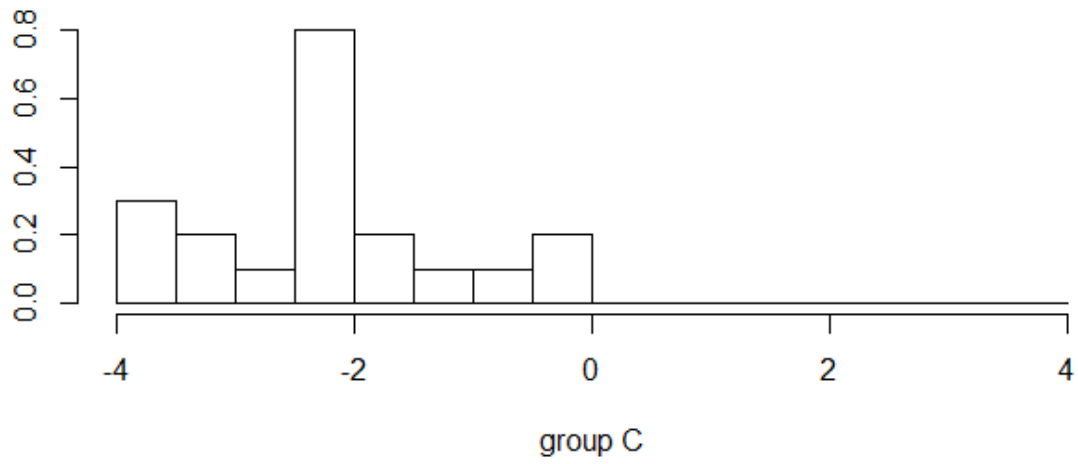

Figure 18. Histogram of the observations of plastral scute shape data for museum-voucher eastern river cooters and northern red bellied cooters. Group C represents data for MV eastern river cooters and group R represents MV northern red bellied cooters.

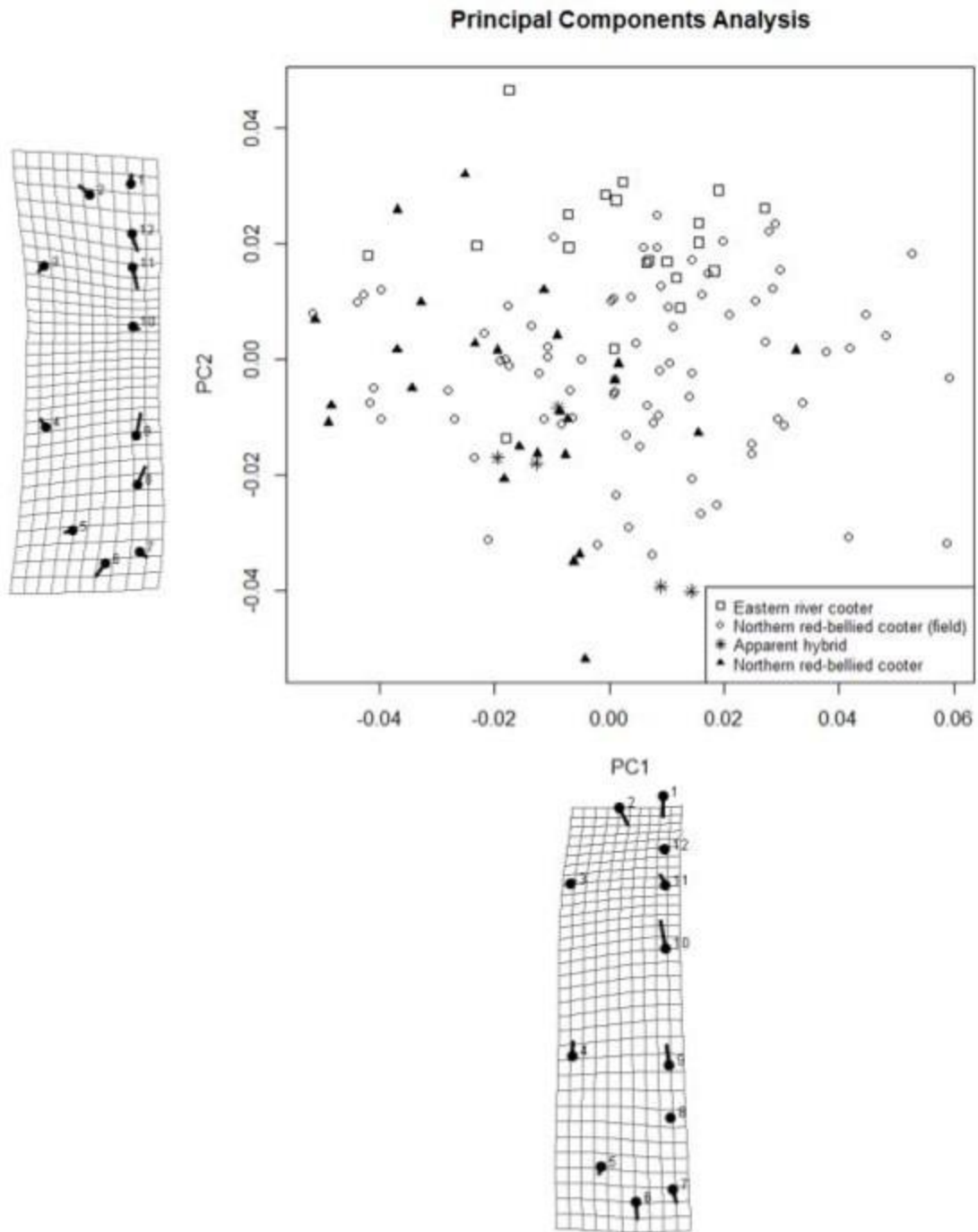

Figure 19. Plot of plastral scute shape data of all applicable specimens based on principal components one and two, comprising 44% of total variance. MV eastern river cooters are represented by hollow squares, MV northern red bellied cooters are represented by solid triangles, field-collected specimens represented by hollow circles, and apparent hybrid specimens are represented by asterisks.

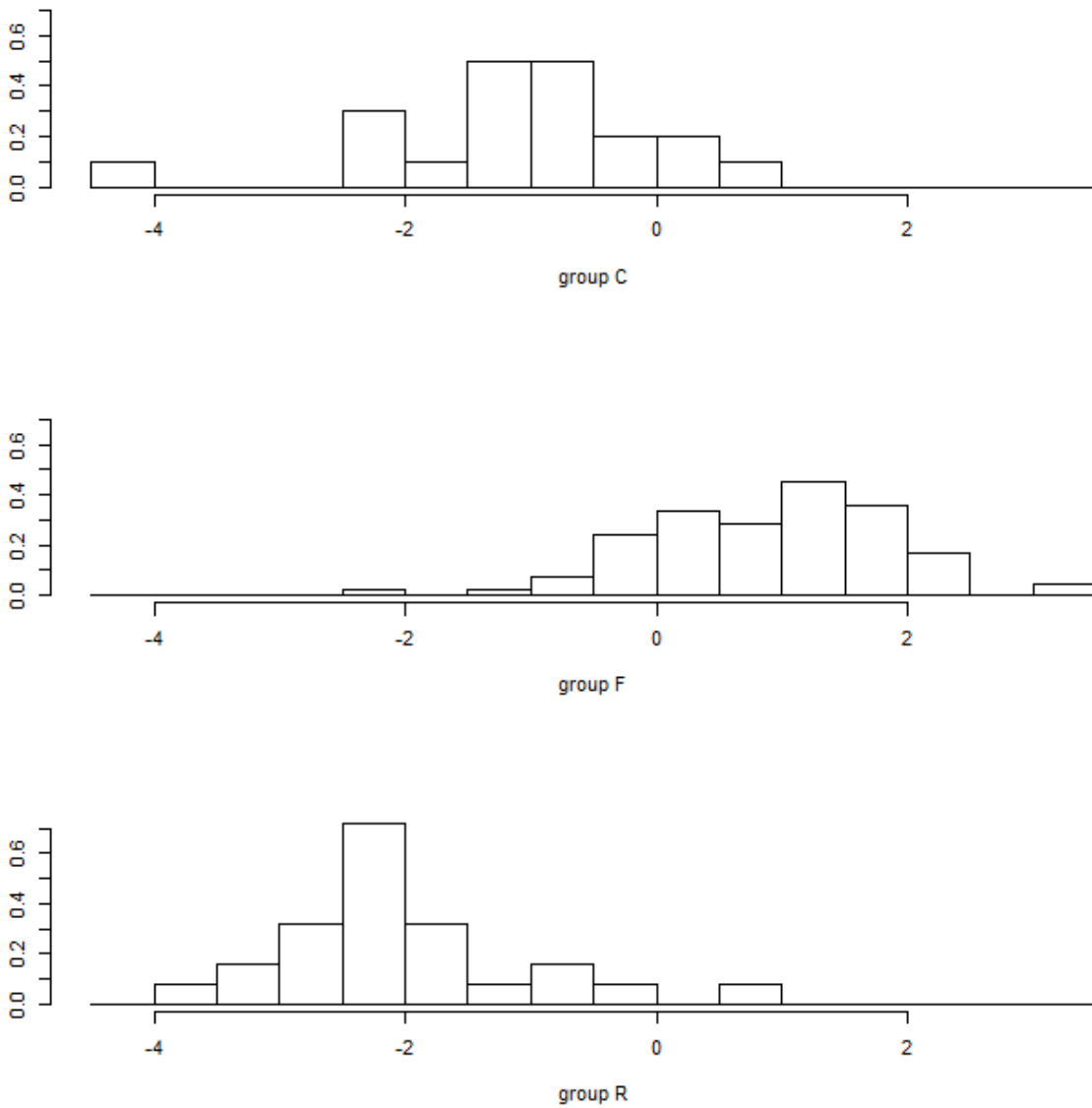

Figure 20. Histogram of the observations of plastral scute shape data in each group on the first linear discriminant dimension, achieving 64% separation. Group C represents data for MV eastern river cooters, group F represents field-collected specimens, and group R represents MV northern red bellied cooters.

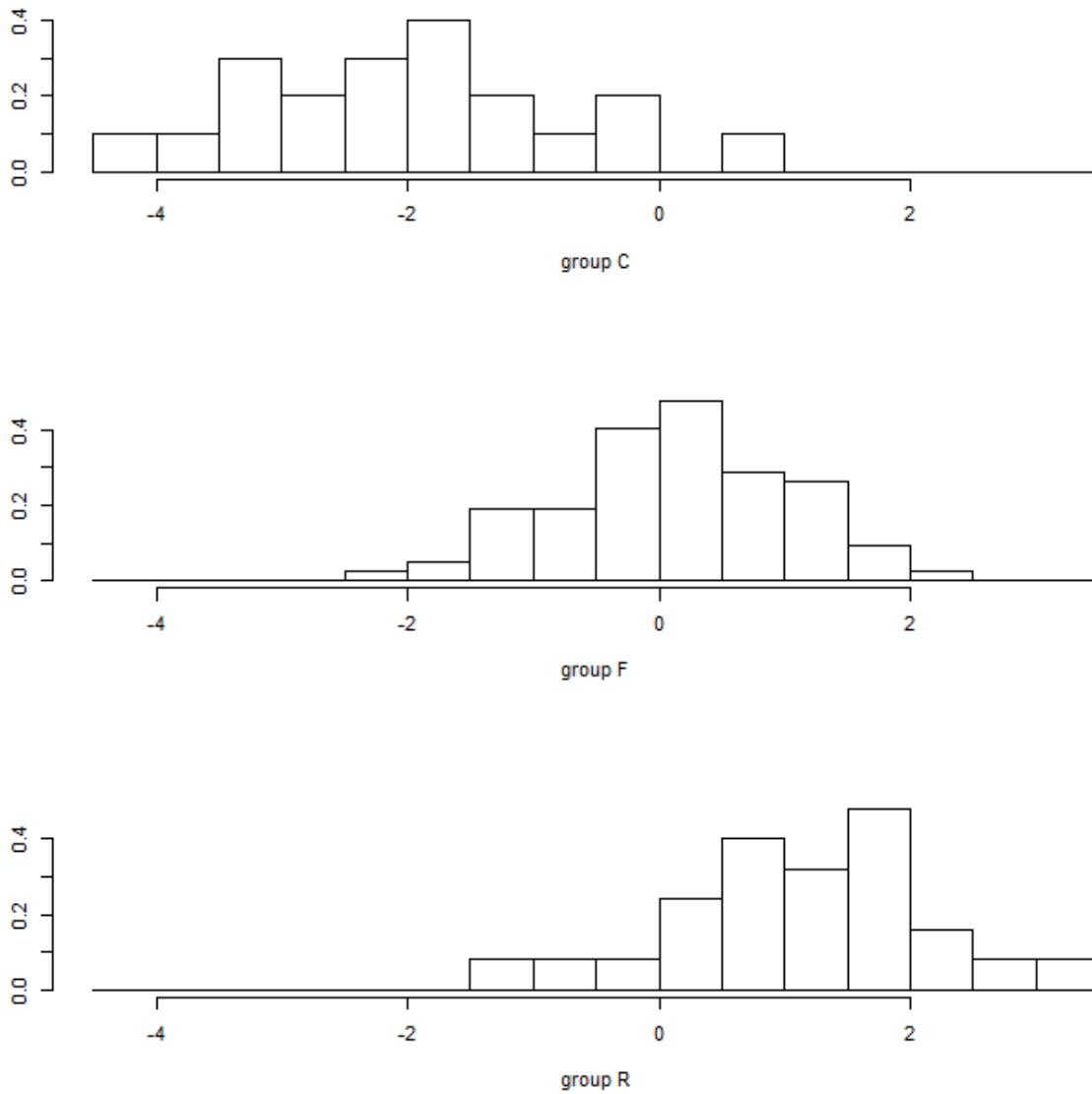

Figure 21. Histogram of the observations of plastral scute shape data in each group on the second linear discriminant dimension, achieving 36% separation. Group C represents data for MV eastern river cooters, group F represents field-collected specimens, and group R represents MV northern red bellied cooters.

Linear Discriminant Analysis

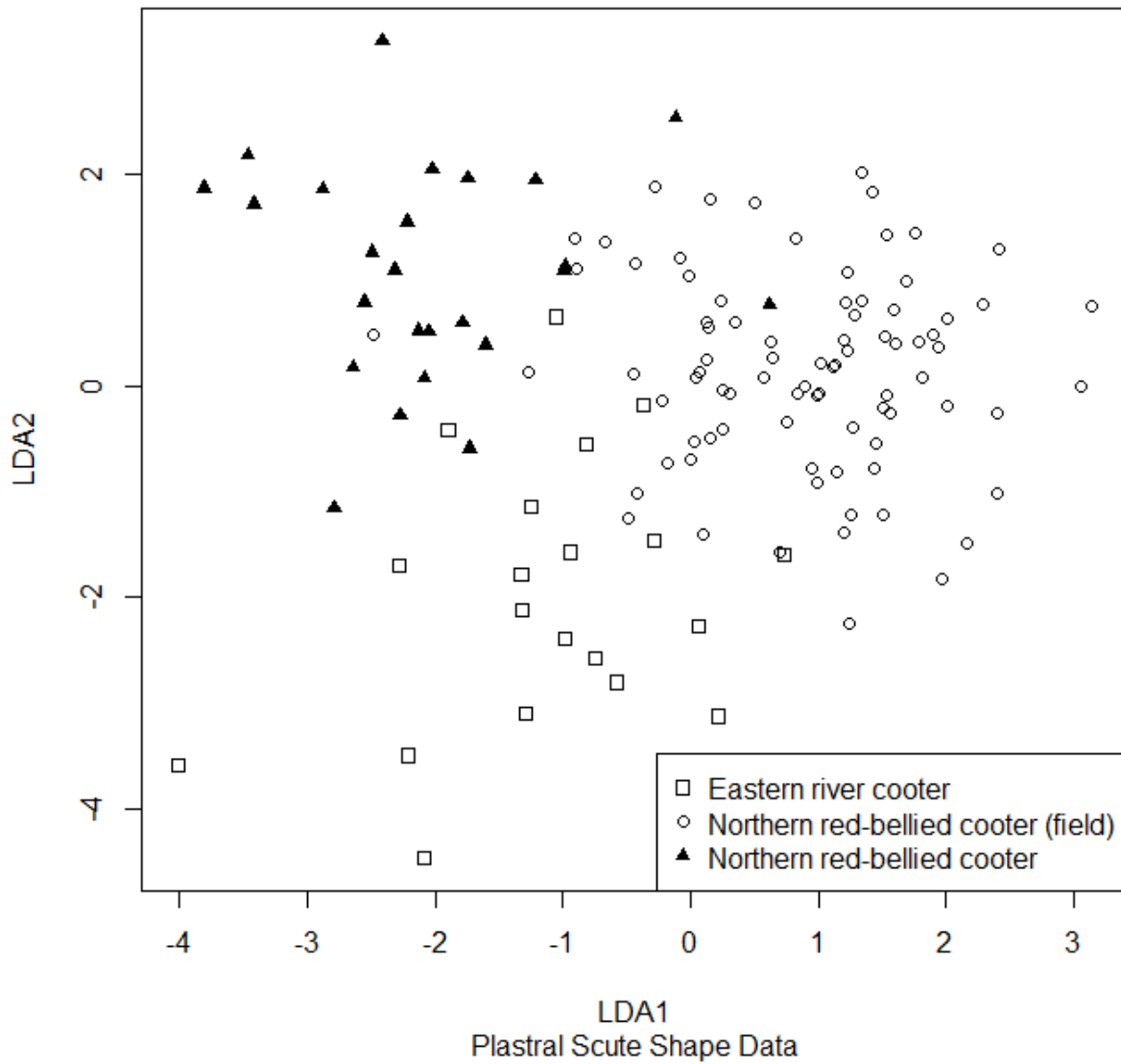
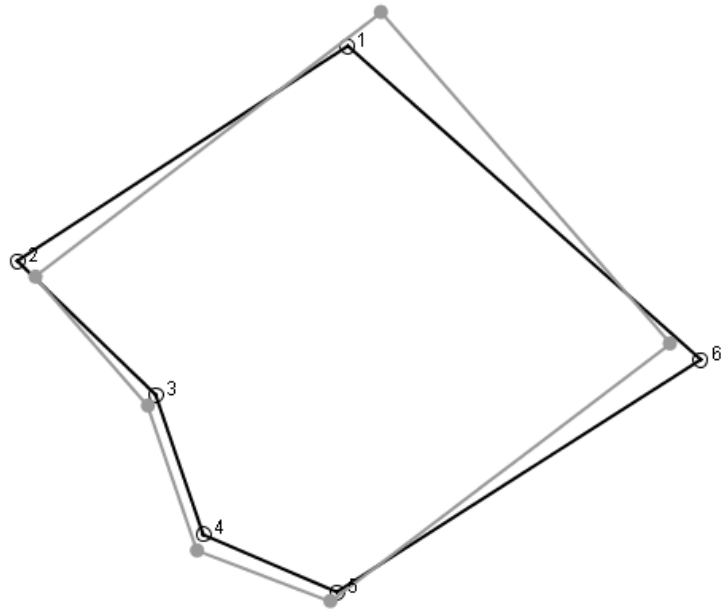
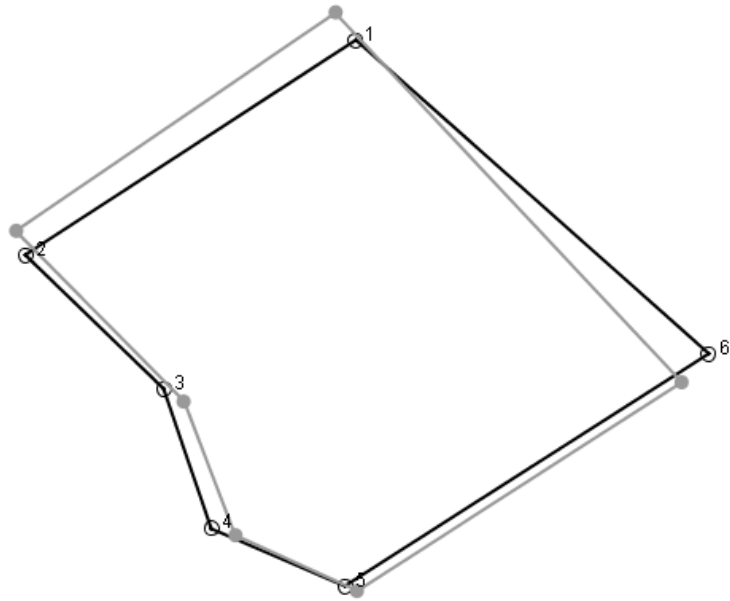

Figure 22. Plot of the observations of plastral scute shape data of each group in the space of the first two linear discriminant functions, with MV eastern river cooters represented by hollow squares, MV northern red bellied cooters represented by solid triangles, and field-collected specimens represented by hollow circles.



PC1

Figure 23. Wireframe graph showing the average jaw shape (as defined by generalized Procrustes superimposition) in black, and the plastron shape defined by principal component 1 in grey.



PC2

Figure 24. Wireframe graph showing the average jaw shape (as defined by generalized Procrustes superimposition) in black, and the plastron shape defined by principal component 2 in grey.

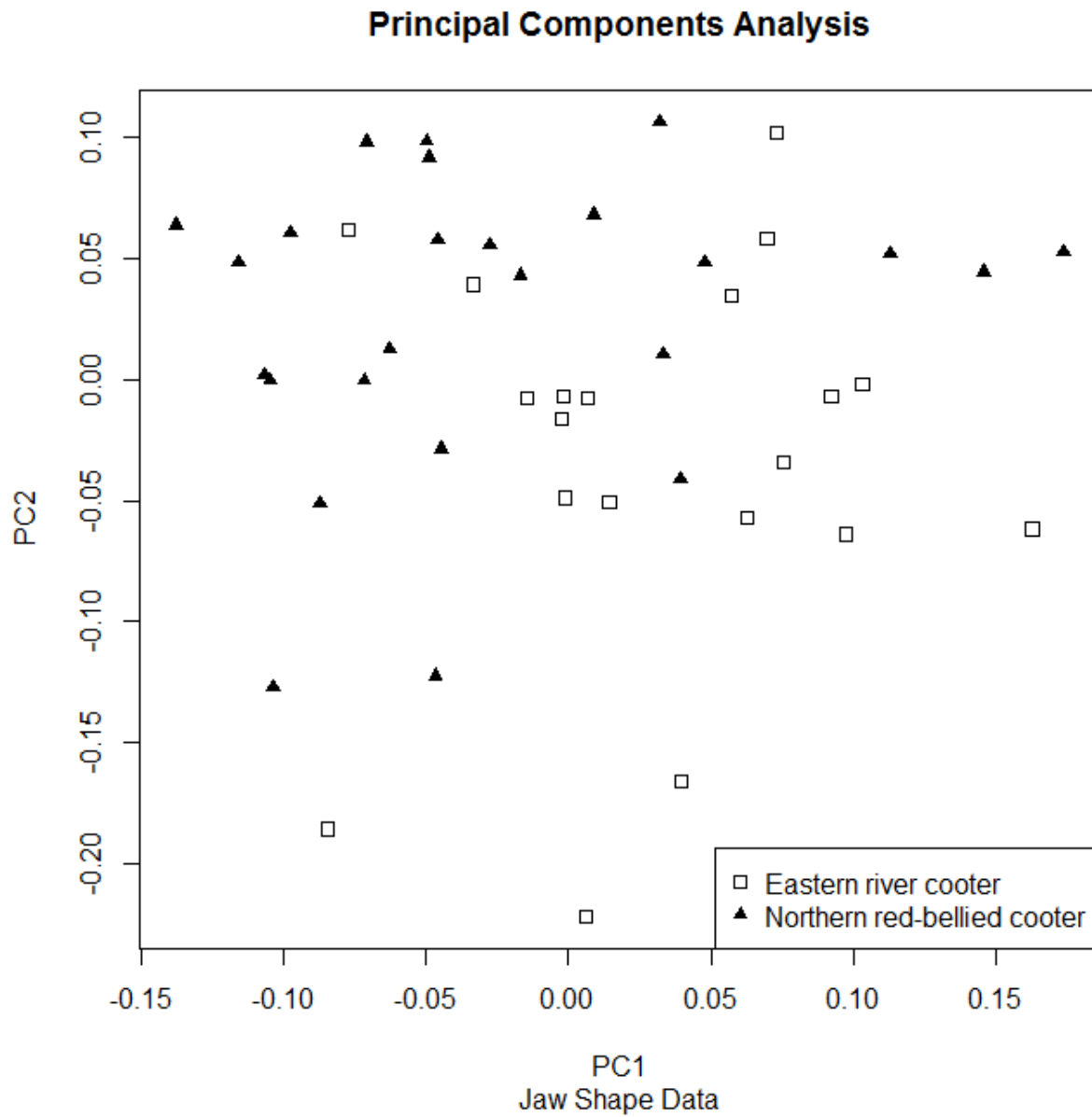

Figure 25. Plot of jaw shape data of MV specimens based on principal components one and two, comprising 70% of total variance. MV eastern river cooters are represented by hollow squares, and MV northern red bellied cooters are represented by solid triangles.

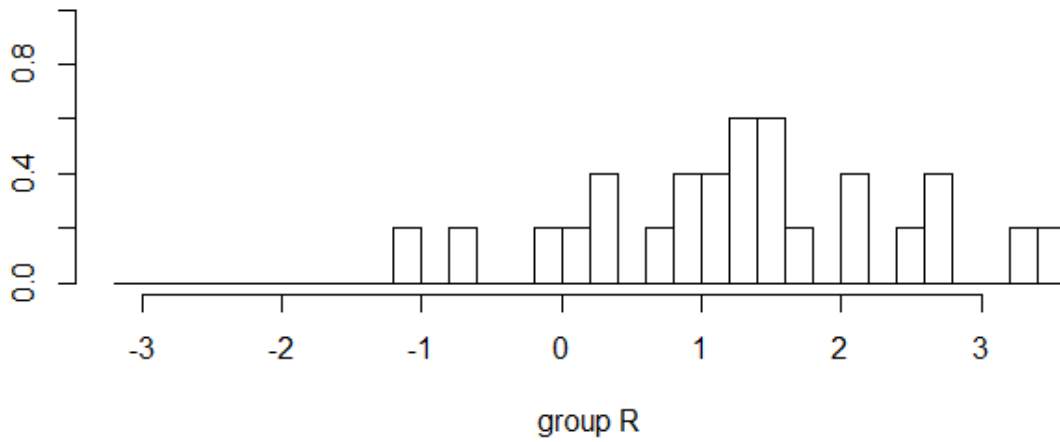
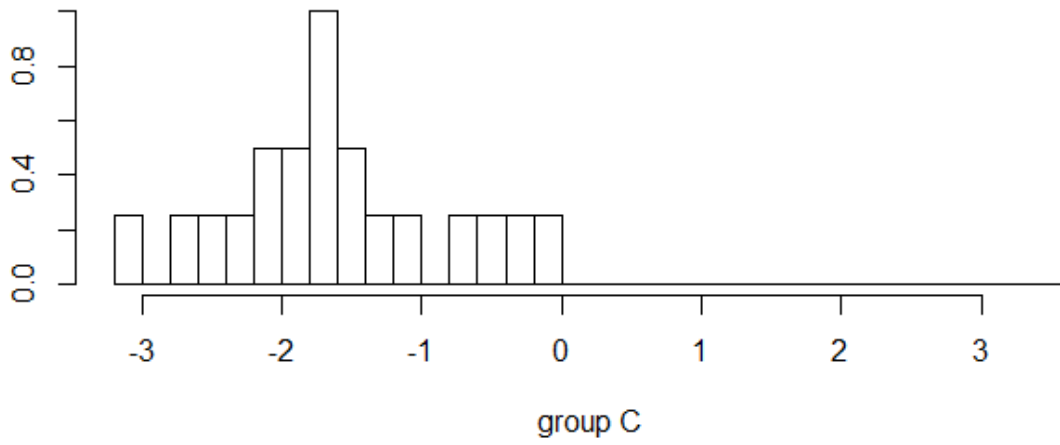

Figure 26. Histogram of the observations of jaw shape data for museum-voucher eastern river cooters and northern red bellied cooters. Group C represents data for MV eastern river cooters and group R represents MV northern red bellied cooters.

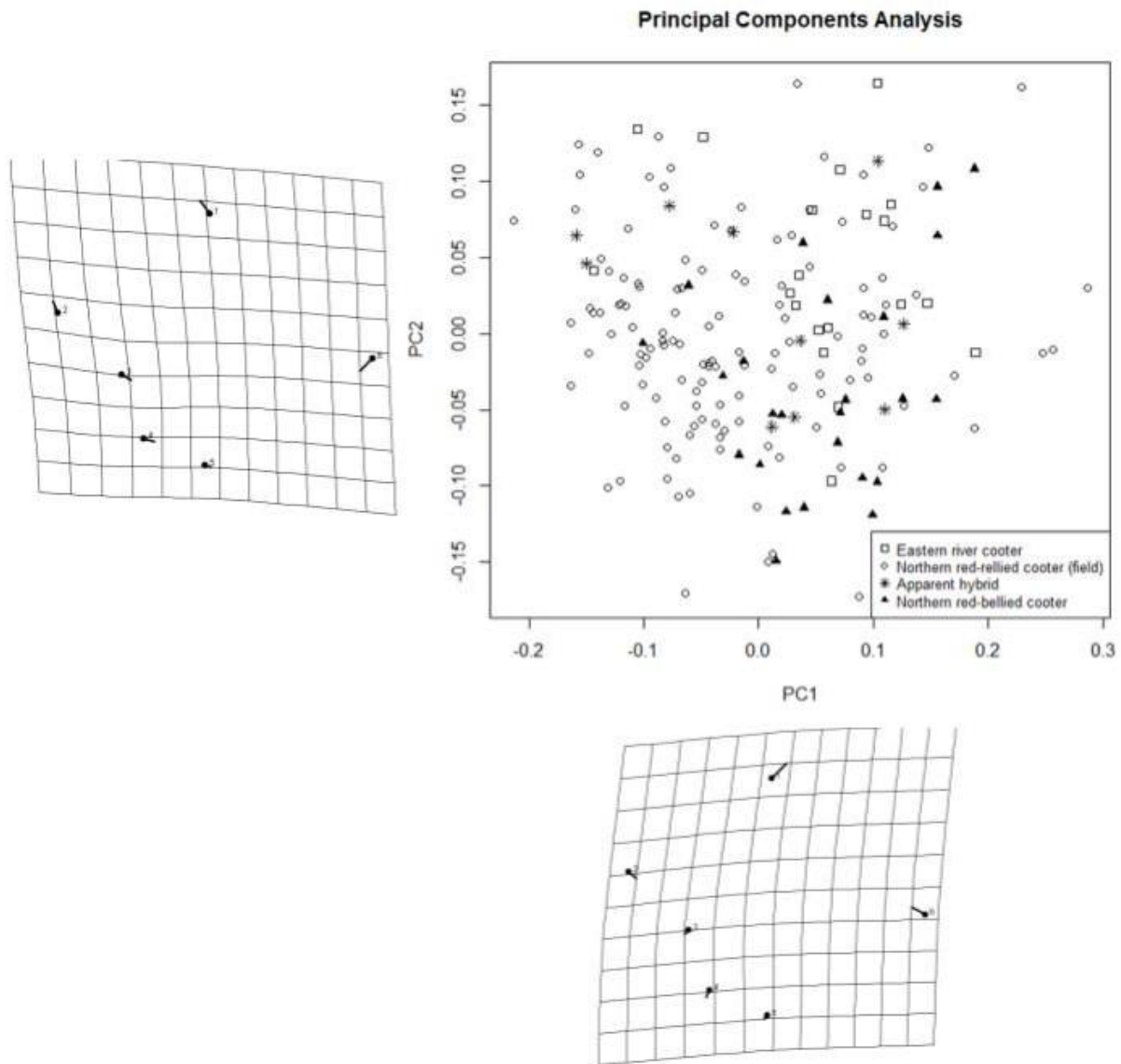

Figure 27. Plot of jaw shape data of all applicable specimens based on principal components one and two, comprising 72% of total variance. MV eastern river cooters are represented by hollow squares, MV northern red bellied cooters are represented by solid triangles, field-collected specimens represented by hollow circles, and apparent hybrid specimens are represented by asterisks.

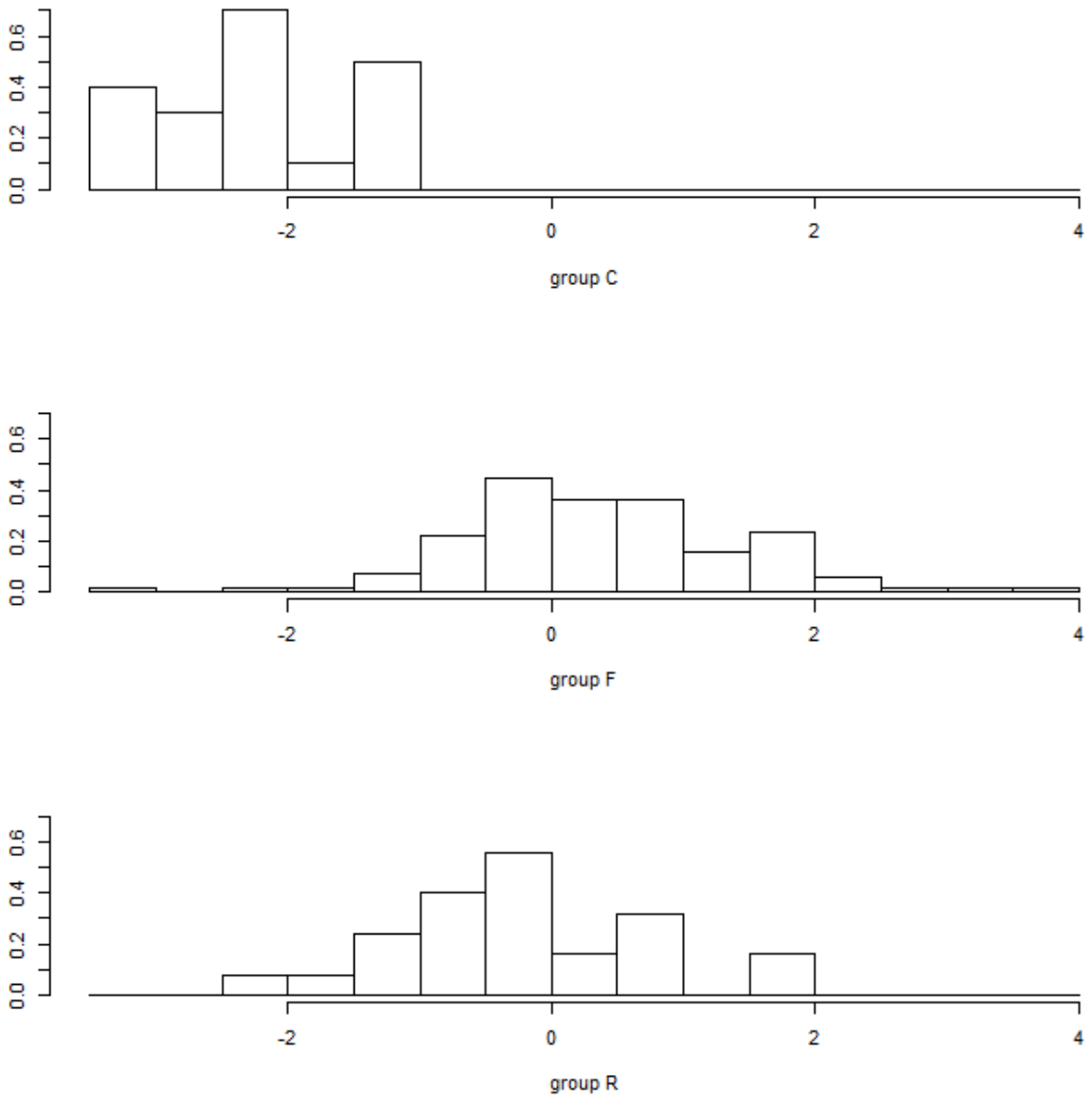

Figure 28. Histogram of the observations of jaw shape data in each group on the first linear discriminant dimension, achieving 78% separation. Group C represents data for MV eastern river cooters, group F represents field-collected specimens, and group R represents MV northern red bellied cooters.

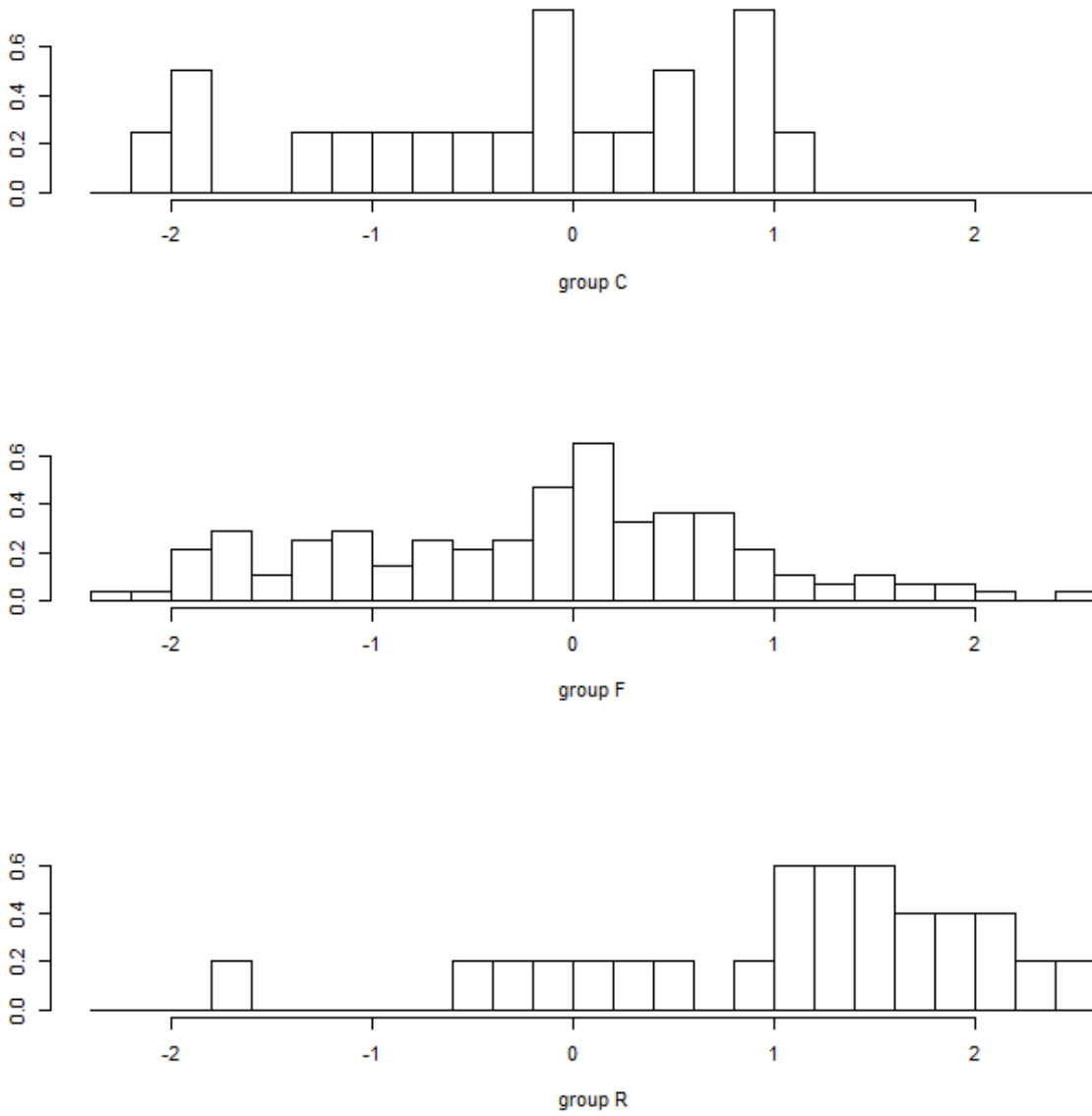

Figure 29. Histogram of the observations of jaw shape data in each group on the second linear discriminant dimension, achieving 22% separation. Group C represents data for MV eastern river cooters, group F represents field-collected specimens, and group R represents MV northern red bellied cooters.

Linear Discriminant Analysis

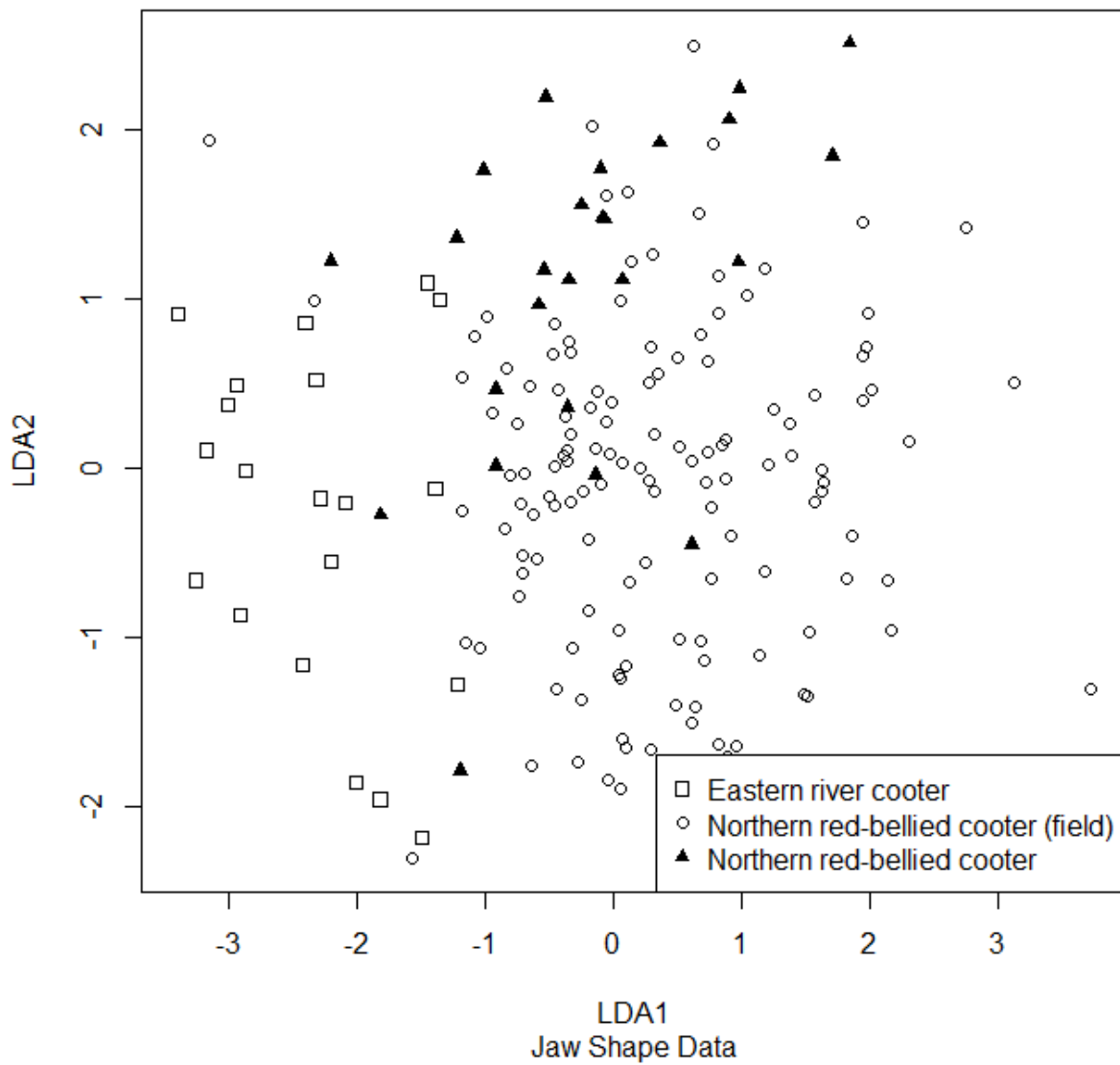

Figure 30. Plot of the observations of jaw shape data of each group in the space of the first two linear discriminant functions, with MV eastern river cooters represented by hollow squares, MV northern red bellied cooters represented by solid triangles and field-collected specimens represented by hollow circles.